

# EPSON

24-Pin Dot  
Matrix Printer

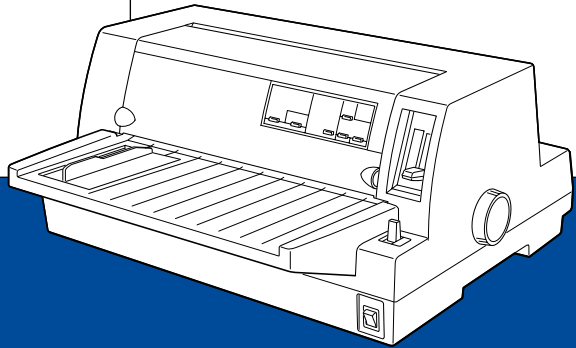

**LQ-680/LQ-680Pro**

## *User's Guide*

# Control Panel Buttons and Lights

- = On
- = Flashing
- = Off

## Font button

Selects the font.

## Condensed button

Turns on and off the condensed mode.

## Reset

When you press both the Font and Condensed buttons simultaneously, the printer clears its buffer and return to its default settings.

## Tear Off/Bin button (LQ-680)

- Advances continuous paper to the tear-off position.
- Feeds continuous paper backward from the tear-off position to the top-of-form position.
- Selects a cut-sheet feeder bin.
- Turns on the card mode to print on postcards and envelopes.

## Tear Off/Bin lights (LQ-680)

- when continuous paper is in the tear-off position.
- when bin 1 of the optional cut-sheet feeder is selected.
- when bin 2 of the optional cut-sheet feeder is selected.
- when the printer is in the card mode.

## Pause button

Stops printing temporarily, and resumes printing when pressed again. When pressed for three seconds, turns on the \*micro adjust mode. To turn off, press again.

## Pause light

- On when the printer is paused.
- Flashes when the printer is in the \*micro adjust mode.
- Flashes when the print head has overheated.

## Paper Out light

- On when no paper is loaded in the selected paper source or paper is not loaded correctly.
- Flashes when paper has not been fully ejected or a paper jam has occurred.

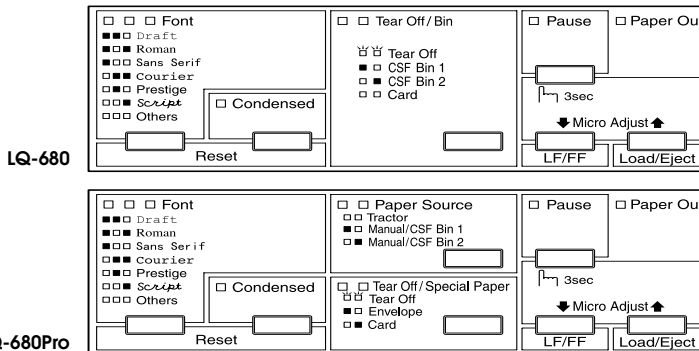

## Paper Source button & lights (LQ-680Pro)

Select a paper source. See Chapter 2.

## Tear Off/Special Paper button (LQ-680Pro)

- Advances continuous paper to the tear-off position.
- Feeds continuous paper backward from the tear-off position to the top-of-form position.
- Turns on the card mode or envelope mode.

## Tear Off/Special Paper lights (LQ-680Pro)

- when continuous paper is in the tear-off position.
- when the printer is in the card mode.
- when the printer is in the envelope mode.

## \*Micro Adjust mode

When you hold down the Pause button for three seconds, the printer enters the micro adjust mode. In this mode, you can press the Lf/FF and Load/Eject buttons to adjust the top-of-form or tear-off position. See Chapter 2.

## Lf/FF button

- Feeds paper line by line when pressing shortly.
- Ejects a single sheet or advances continuous paper to the next top-of-form position when held down.

## Load/Eject button

- Loads a single sheet of paper.
- Ejects a single sheet of paper if a sheet is loaded.
- Loads continuous paper from the standby position.
- Feeds continuous paper backward to the standby position.

# EPSON®

24-Pin Dot Matrix Printer

## LQ-680 / LQ-680Pro

All rights reserved. No part of this publication may be reproduced, stored in a retrieval system, or transmitted in any form or by any means, electronic, mechanical, photocopying, recording, or otherwise, without the prior written permission of SEIKO EPSON CORPORATION. The information contained herein is designed only for use with this EPSON printer. EPSON is not responsible for any use of this information as applied to other printers.

Neither SEIKO EPSON CORPORATION nor its affiliates shall be liable to the purchaser of this product or third parties for damages, losses, costs, or expenses incurred by the purchaser or third parties as a result of: accident, misuse, or abuse of this product or unauthorized modifications, repairs, or alterations to this product, or (excluding the U.S.) failure to strictly comply with SEIKO EPSON CORPORATION's operating and maintenance instructions.

SEIKO EPSON CORPORATION shall not be liable for any damages or problems arising from the use of any options or any consumable products other than those designated as Original EPSON Products or EPSON Approved Products by SEIKO EPSON CORPORATION.

EPSON and EPSON ESC/P are registered trademarks of SEIKO EPSON CORPORATION.

Microsoft, Windows, and Windows NT are registered trademarks of Microsoft Corporation.

IBM is a registered trademark of International Business Machines Corporation.

*General Notice: Other product names used herein are for identification purposes only and may be trademarks of their respective owners. EPSON disclaims any and all rights in those marks.*

Copyright © 2000 by SEIKO EPSON CORPORATION, Nagano, Japan.



Printed on Recycled Paper.

## User's Guide

---

## **FCC Compliance Statement For United States Users**

This equipment has been tested and found to comply with the limits for a Class B digital device, pursuant to Part 15 of the FCC Rules. These limits are designed to provide reasonable protection against harmful interference in a residential installation. This equipment generates, uses, and can radiate radio frequency energy and, if not installed and used in accordance with the instructions, may cause harmful interference to radio or television reception. However, there is no guarantee that interference will not occur in a particular installation. If this equipment does cause interference to radio and television reception, which can be determined by turning the equipment off and on, the user is encouraged to try to correct the interference by one or more of the following measures.

- Reorient or relocate the receiving antenna
- Increase the separation between the equipment and receiver
- Connect the equipment into an outlet on a circuit different from that to which the receiver is connected
- Consult the dealer or an experienced radio/TV technician for help.

### **WARNING**

The connection of a non-shielded equipment interface cable to this equipment will invalidate the FCC Certification of this device and may cause interference levels which exceed the limits established by the FCC for this equipment. It is the responsibility of the user to obtain and use a shielded equipment interface cable with this device. If this equipment has more than one interface connector, do not leave cables connected to unused interfaces.

Changes or modifications not expressly approved by the manufacturer could void the user's authority to operate the equipment.

### **For Canadian Users**

This Class B digital apparatus complies with Canadian ICES-003.

Cet appareil numérique de la classe B est conforme à la norme NMB-003 du Canada.

# DECLARATION of CONFORMITY

According to 47CFR, Part 2 and 15 for Class B Personal Computers and Peripherals; and/or CPU Boards and Power Supplies used with Class B Personal Computers:

We: EPSON AMERICA, INC.  
Located at: MS 6-43  
3840 Kilroy Airport Way  
Long Beach, CA 90806-2469  
Telephone: (562)290-5254

Declare under sole responsibility that the product identified herein, complies with 47CFR Part 2 and 15 of the FCC rules as a Class B digital device. Each product marketed, is identical to the representative unit tested and found to be compliant with the standards. Records maintained continue to reflect the equipment being produced can be expected to be within the variation accepted, due to quantity production and testing on a statistical basis as required by 47CFR §2.909 Operation is subject to the following two conditions: (1) this device may not cause harmful interference, and (2) this device must accept any interference received, including interference that may cause undesired operation.

Trade Name: EPSON  
Type of Product: Dot Matrix Printer  
Model: P220A/P220B



---

# Contents

---

## Getting to Know Your Printer

---

Important Safety Instructions .....	2
Print Head Caution Symbol .....	4
ENERGY STAR Compliance .....	4
For United Kingdom Users .....	4
Use of options .....	4
Safety information .....	5
Warnings, Cautions, and Notes .....	6

---

## Chapter 1 Setting Up the Printer

---

Unpacking the Printer .....	1-2
Choosing a Place for the Printer .....	1-3
Assembling the Printer .....	1-5
Attaching the paper guide .....	1-5
Plugging in the Printer .....	1-5
Connecting the Printer to Your Computer .....	1-6
Installing or Replacing the Ribbon Cartridge .....	1-8
Installing the Printer Software .....	1-12
Installing the printer software in Windows 98, 95, 2000, or NT 4.0 1-13	
Installing the printer software in Windows 3.1 or NT 3.5x For DOS programs .....	1-14 1-16

---

## Chapter 2 Paper Handling

---

Selecting a Paper Source .....	2-2
Paper source and paper types .....	2-3
Setting the paper release lever (LQ-680) .....	2-4
Setting the Paper Source button (LQ-680Pro) .....	2-5
Adjusting the Paper Thickness Lever .....	2-6
Using Continuous Paper .....	2-8

Positioning your continuous paper supply . . . . .	2-8
Loading continuous paper with the tractor . . . . .	2-9
Using the tear-off function . . . . .	2-14
Removing continuous paper . . . . .	2-17
Using Continuous Multipart Forms . . . . .	2-17
Using Overlapping Multipart Forms (LQ-680Pro) . . . . .	2-18
Using Labels . . . . .	2-19
Using Single Sheets . . . . .	2-20
Using Single-Sheet Multipart Forms . . . . .	2-23
Using Envelopes . . . . .	2-24
Using Postcards . . . . .	2-25
Switching Between Continuous Paper and Single Sheets . . . . .	2-26
Switching to single sheets . . . . .	2-26
Switching to continuous paper . . . . .	2-28
Using Micro Adjust . . . . .	2-28
Adjusting the loading position . . . . .	2-28
Adjusting the tear-off position . . . . .	2-31
Adjusting the printing position . . . . .	2-32

### **Chapter 3 Using the Printer Software**

---

About Your Printer Software . . . . .	3-2
Using the Printer Driver With Windows 98 or 95 . . . . .	3-3
Accessing the printer driver from Windows applications	3-3
Accessing the printer driver from the Start menu . . . . .	3-5
Changing the printer driver settings . . . . .	3-5
Using the Printer Driver With Windows 3.1 . . . . .	3-6
Accessing the printer driver from Windows applications	3-6
Accessing the printer driver from the Control Panel . . . . .	3-8
Changing the Printer driver settings . . . . .	3-8
Using the Printer Driver With Windows 2000 and NT 4.0 . . . . .	3-9
Accessing the printer driver from Windows applications	3-9
Accessing the printer driver from the Start menu . . . . .	3-11
Changing the printer driver settings . . . . .	3-12
Using the Printer Driver With Windows NT 3.5x . . . . .	3-13
Accessing the printer driver from Windows applications	3-13
Accessing the printer driver from the Control Panel . . . . .	3-15



Changing the Printer driver settings . . . . .	3-16
Printer Driver Settings Overview . . . . .	3-17
Using the EPSON Remote! Utility . . . . .	3-19
Installing EPSON Remote! . . . . .	3-19
Accessing EPSON Remote! . . . . .	3-19
Using the EPSON Status Monitor 3 Utility . . . . .	3-20
Setting up EPSON Status Monitor 3 . . . . .	3-20
Accessing EPSON Status Monitor 3. . . . .	3-22

## ***Chapter 4 Changing Printer Settings From the Printer's Control Panel***

---

Selecting a Built-In Font and Pitch . . . . .	4-2
About Your Printer's Default Settings . . . . .	4-3
Changing default settings . . . . .	4-9

## ***Chapter 5 Troubleshooting***

---

Using the Error Indicators . . . . .	5-2
Problems and Solutions . . . . .	5-4
Power supply problems. . . . .	5-5
Single-sheet paper loading or feeding problems. . . . .	5-6
Continuous paper loading or feeding problems . . . . .	5-8
Printing position problems . . . . .	5-9
Printing or printout quality problems. . . . .	5-11
Clearing Paper Jams . . . . .	5-16
Aligning Vertical Lines in Your Printout. . . . .	5-17
Printing a Self Test. . . . .	5-18
Printing a Hex Dump . . . . .	5-19

## ***Appendix A Enhancing Your Printer With Options***

---

Cut-Sheet Feeders . . . . .	A-2
Installing the cut-sheet feeder. . . . .	A-3
Loading paper from the cut-sheet feeder . . . . .	A-6
Switching between the tractor and the cut-sheet feeder. . .	A-13

Loading paper manually from the paper guide . . . . .	A-14
Roll Paper Holder . . . . .	A-15
Installing the roll paper holder . . . . .	A-15
Loading a roll of paper . . . . .	A-17
Removing roll paper . . . . .	A-18
Optional interface cards . . . . .	A-19
Installing an interface card . . . . .	A-20

---

## ***Appendix B Cleaning and Transporting the Printer***

Cleaning the Printer . . . . .	B-2
Transporting the Printer . . . . .	B-3

---

## ***Appendix C Specifications***

Printer Specifications . . . . .	C-2
Mechanical . . . . .	C-2
Electronic . . . . .	C-4
Electrical . . . . .	C-6
Environmental . . . . .	C-6
Paper . . . . .	C-6
Printable area . . . . .	C-11
Safety approvals . . . . .	C-14
CE marking . . . . .	C-14
Command Lists . . . . .	C-15
EPSON ESC/P2 control codes . . . . .	C-15
IBM 2390 Plus emulation control codes . . . . .	C-16

---

## ***Appendix D Customer Support Information***

Contacting Customer Support . . . . .	D-2
For Users in North America . . . . .	D-3
For Users in the United Kingdom and the Republic of Ireland . . . . .	D-4
For Users in Australia . . . . .	D-6
For Users in India . . . . .	D-7
For Users in Malaysia . . . . .	D-8

For Users in Singapore .....D-8  
For Users in Hong Kong.....D-9  
For Users in the Philippines.....D-10

***Glossary***

---

***Index***

---



---

# ***Getting to Know Your Printer***

Your EPSON® LQ-680/LQ-680Pro 24-pin dot matrix printer provides high-quality printing and great performance in a compact design.

Features include:

- ❑ The ability to handle a wide range of paper types, including continuous paper, multipart forms with one original and up to five copies, labels, single sheets, envelopes, and postcards
- ❑ High-speed printing of up to 413 cps (characters per second) at 10 characters per inch

Your printer also comes with printer driver software, the EPSON Status Monitor 3 utility for Microsoft® Windows® 98, 95, 2000 and NT 4.0, that lets you check the status of your printer quickly and easily, and other software. In addition, many other options are available to suit your individual needs.

---

## ***Important Safety Instructions***

Read all of these instructions and save them for later reference. Follow all warnings and instructions marked on the printer.

- ❑ Do not place the printer on an unstable surface or near a radiator or heat source.
- ❑ Place the printer on a flat surface. The printer will not operate properly if it is tilted or at an angle.
- ❑ Do not block or cover the openings in the printer's cabinet. Do not insert objects through the slots.
- ❑ Use only the type of power source indicated on the printer's label.
- ❑ Connect all equipment to properly grounded power outlets. Avoid using outlets on the same circuit as photocopiers or air control systems that regularly switch on and off.
- ❑ Do not use a damaged or frayed power cord.
- ❑ If you use an extension cord with the printer, make sure the total ampere rating of all devices plugged into the extension cord does not exceed the cord's ampere rating. Also, make sure the total of all devices plugged into the wall outlet does not exceed the wall outlet's ampere rating.
- ❑ Unplug the printer before cleaning, and clean it with a damp cloth only.
- ❑ Do not spill liquid on the printer.
- ❑ Except as specifically explained in this guide, do not attempt to service the printer yourself.

- ❑ Unplug the printer and refer servicing to qualified personnel under the following conditions:

If the power cord or plug is damaged; if liquid has entered the printer; if the printer has been dropped or the cabinet damaged; or if the printer does not operate normally or exhibits a distinct change in performance. Adjust only those controls that are covered by the operating instructions.

- ❑  Printer parts marked with this symbol may be hot. Turn off the printer and let it cool for a few minutes before you touch any printer part marked with this symbol.

- ❑ If you plan to use the printer in Germany, observe the following:

To provide adequate short-circuit protection and over-current protection for this printer, the building installation must be protected by a 10 or 16 amp circuit breaker.

***Note for German-speaking users:***

*Bei Anschluss des Druckers an die Stromversorgung muss sichergestellt werden, dass die Gebäudeinstallation mit einer 10 A- oder 16 A-Sicherung abgesichert ist.*

---

## ***Print Head Caution Symbol***



The symbol on the print head indicates that this part may be hot. Never touch the print head just after the printer has been used. Let the print head cool for a few minutes before touching it.

---

## ***ENERGY STAR Compliance***



As an ENERGY STAR Partner, EPSON has determined that this product meets the ENERGY STAR guidelines for energy efficiency.

The International ENERGY STAR Office Equipment program is a voluntary partnership with the computer and office equipment industry to promote the introduction of energy-efficient personal computers, monitors, printers, fax machines, copiers, and scanners in an effort to reduce air pollution caused by power generation.

---

## ***For United Kingdom Users***

### ***Use of options***

Epson (UK) Limited shall not be liable against any damages or problems arising from the use of any options or consumable products other than those designated as Original EPSON Products or EPSON Approved Products by Epson (UK) Limited.



## Safety information



### **Warning:**

*This appliance must be earthed. Refer to the rating plate for voltage and check that the appliance voltage corresponds to the supply voltage.*

**Important:** *The wires in the mains lead fitted to this appliance are coloured in accordance with the following code:*

*Green and yellow — Earth*

*Blue — Neutral*

*Brown — Live*

### **If you have to fit a plug:**

As the colours of the mains lead of this appliance may not match coloured markings used to identify the terminals in a plug, please proceed as follows:

The green and yellow wire must be connected to the terminal in the plug which is marked with the letter E or the Earth symbol ( $\perp$ ).

The blue wire must be connected to the terminal in the plug marked with the letter N.

The brown wire must be connected to the terminal in the plug marked with the letter L.

If damage occurs to the plug, replace the cord set or consult a qualified electrician.

Replace fuses only with a fuse of the correct size and rating.

---

## **Warnings, Cautions, and Notes**

This guide uses the following conventions:



*Warnings must be followed to avoid bodily injury.*



*Cautions must be observed to avoid damage to your equipment.*

*Notes contain important information and useful tips on the operation of your printer.*

Unpacking the Printer . . . . . 1-2

Choosing a Place for the Printer . . . . . 1-3

Assembling the Printer . . . . . 1-5

    Attaching the paper guide . . . . . 1-5

Plugging in the Printer . . . . . 1-5

Connecting the Printer to Your Computer . . . . . 1-6

Installing or Replacing the Ribbon Cartridge . . . . . 1-8

Installing the Printer Software . . . . . 1-12

    Installing the printer software in Windows 98, 95,  
    2000, or NT 4.0 . . . . . 1-13

    Installing the printer software in Windows 3.1  
    or NT 3.5x . . . . . 1-14

    For DOS programs . . . . . 1-16

---

## Unpacking the Printer

Besides this guide, your printer box should include an EPSON printer software CD-ROM, a Notice Sheet, and the following items:

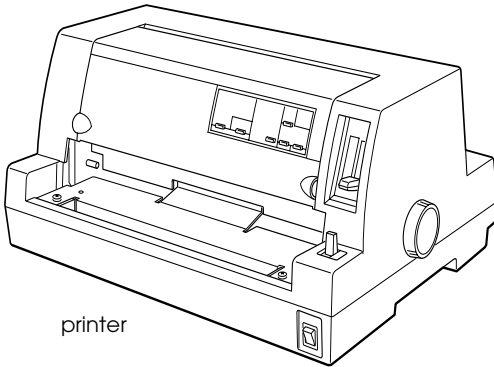

printer

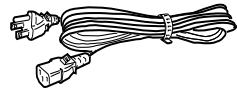

power cord

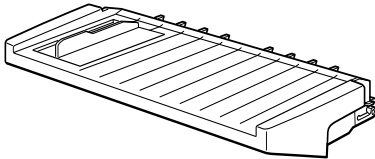

paper guide

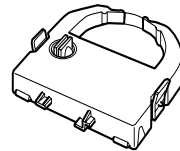

ribbon cartridge

### **Note:**

*Depending on your printer model, the power cord may be permanently attached to the printer. Also, the shape of the power cord plug varies depending on the country of purchase; be sure the plug you have is the right one for your location.*



### **Caution:**

*There are several models of the printer designed for different voltages, and it is not possible to adjust the printer for use with another voltage. If the label on the back of the printer does not show the correct voltage for your country, contact your dealer.*

You must remove all protective materials packed around and inside your printer before you set it up and turn on the power. Follow the directions on the Notice Sheet (packed with the printer) to remove these materials.

Save all packing and protective materials in case you need to ship the printer in the future. It should always be transported in its original packaging or equivalent materials.

---

## ***Choosing a Place for the Printer***

Follow the guidelines below when selecting a location for your printer.

- Place the printer on a flat, stable surface. The printer will not operate properly if it is tilted or at an angle.
- Leave adequate room around the printer for easy operation and maintenance.
- Avoid using or storing the printer in places subject to rapid changes in temperature and humidity. Keep it away from direct sunlight, strong light, heat sources, or excessive moisture or dust.
- Avoid places subject to shocks and vibrations.
- Place the printer near a wall outlet where you can easily unplug the power cord.

***Note for French-speaking users:***

*Placez l'imprimante près d'une prise de contact où la fiche peut être débranchée facilement.*

- ❑ Avoid electrical outlets controlled by wall switches or automatic timers. An interruption of power can erase information in the memory of your printer or computer. Also avoid outlets on the same circuit as large motors or other appliances that can cause voltage fluctuations.
- ❑ Keep the entire computer system away from potential sources of electromagnetic interference, such as loudspeakers or the base units of cordless telephones.
- ❑ Use a grounded power outlet; do not use an adapter plug.
- ❑ Make sure the paper path is clear and unobstructed before you print on continuous paper.
- ❑ Position your printer's power cord and interface cable so they do not interfere with paper feeding.

If you plan to use a printer stand, follow these guidelines:

- ❑ Use a stand that supports at least 20 kg (44.1 lb).
- ❑ Never use a stand that tilts the printer. The printer should always be kept level.
- ❑ If possible, secure the printer's power cord and interface cable to a leg of the printer stand so they do not interfere with paper feeding.

---

## Assembling the Printer

1

### Attaching the paper guide

To attach the paper guide, slide the slots on the paper guide all the way onto the mounting pegs in the printer as shown below.

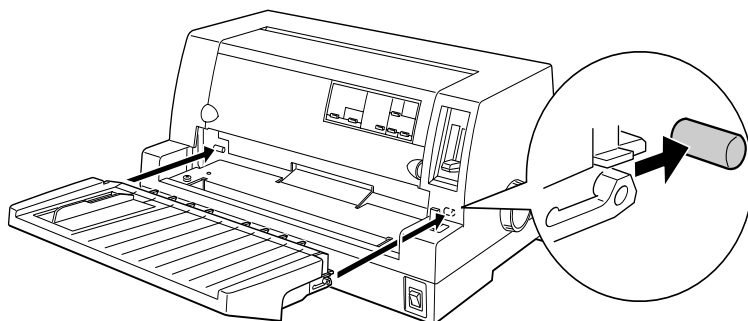

---

### Plugging in the Printer

1. Make sure the printer is turned off.
2. Check the label on the back of the printer to make sure its voltage matches that of your electrical outlet. Also make sure the plug on your printer's power cord matches your electrical outlet.



**Warning:**

*It is not possible to change the printer's voltage. If the rated voltage and your outlet voltage do not match, contact your dealer for assistance. Do not plug in the power cord.*

3. If the power cord is not attached to the printer, plug the appropriate end into the AC inlet on the back of the printer.
4. Plug the power cord into a properly grounded electrical outlet.

---

## ***Connecting the Printer to Your Computer***

Your printer has a standard IEEE-1284 compatible parallel interface connection and an optional interface.

If your computer requires a different type of printer interface, try one of the Type B optional interfaces described in "Optional interface cards" on page A-19.

Follow the steps below to connect the printer to your computer using a parallel interface connector, or a ground wire connector.

1. Make sure both the printer and computer are turned off.
2. Plug the cable connector securely into the parallel interface connector.

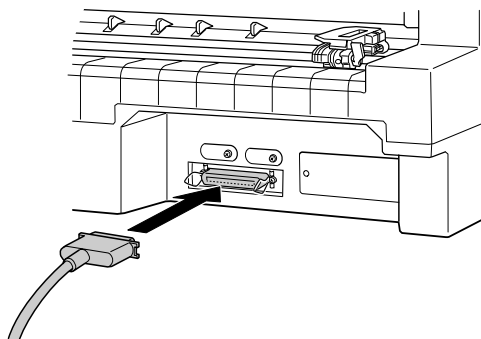



3. Squeeze the wire clips together until they lock in place on both sides of the connector.

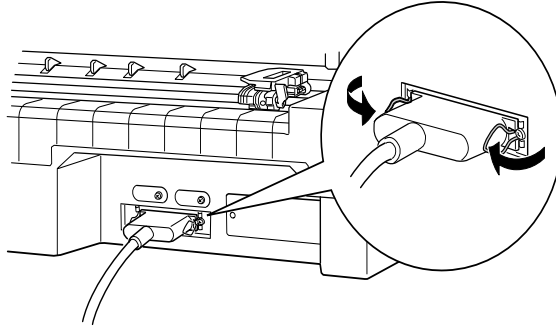

4. If your cable has a ground wire, connect it to the printer's ground connector as shown below.

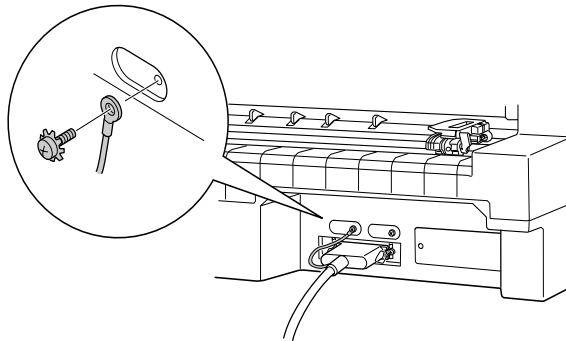

5. Plug the other end of the cable into the computer.

---

## Installing or Replacing the Ribbon Cartridge

EPSON recommends the use of genuine EPSON Ribbon Cartridges (S015016).



**Warning:**

*You may touch the print head by hand to install or replace the ribbon cartridge. If you have just used the printer, the print head may be hot; let it cool for a few minutes before proceeding.*

1. Make sure the printer is turned off.
2. Open the printer cover by gently lifting up the notch on the both sides.

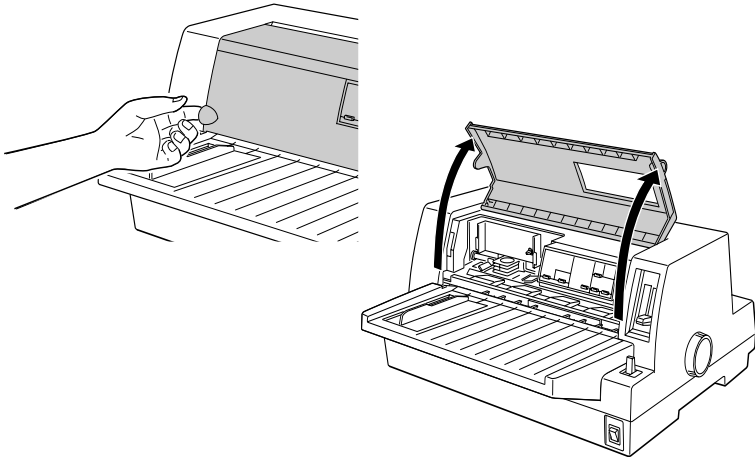

3. The print head should be in the replacement position indicated by an indentation in the front metal plate, as shown below.

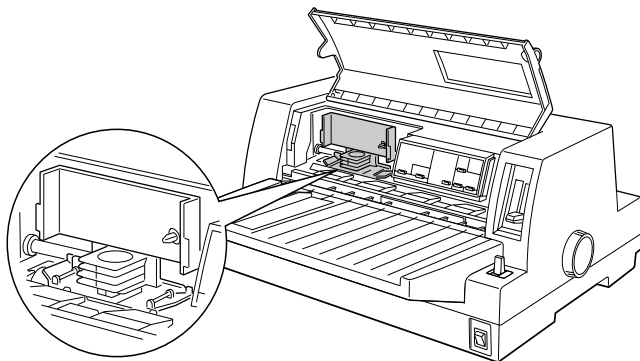

If it is not, close the printer cover and turn the printer on to move the print head to the replacement position. Wait a few seconds, then turn the printer off again and open the printer cover.



**Caution:**

*Following the steps below while the printer is turned on can damage the printer.*

4. If a used ribbon cartridge is already installed, squeeze the tabs on each side of the cartridge, and pull the cartridge out of the printer. Properly dispose the used ribbon and cartridge.

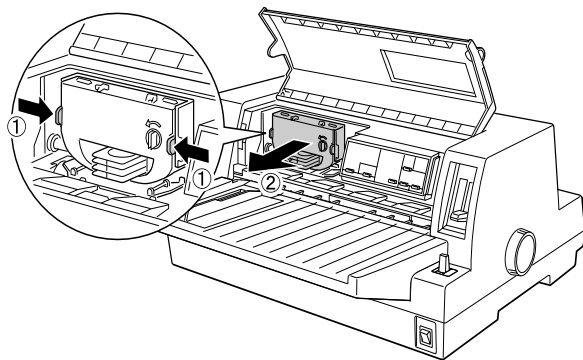

5. Turn the ribbon-tightening knob on the new cartridge in the direction of the arrow to take up any slack in the ribbon.

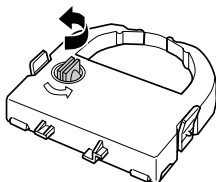

6. Hold the ribbon cartridge with the exposed ribbon down and the ribbon-tightening knob facing you, and guide the ribbon under the print head. Then snap the cartridge into place so that the tabs on both sides of the cartridge fit into the notches in the cartridge holder.

7. Hold the ribbon cartridge by its handle and push it firmly down into position; then press on both ends of the cartridge to make sure the plastic hooks fit into the slots.

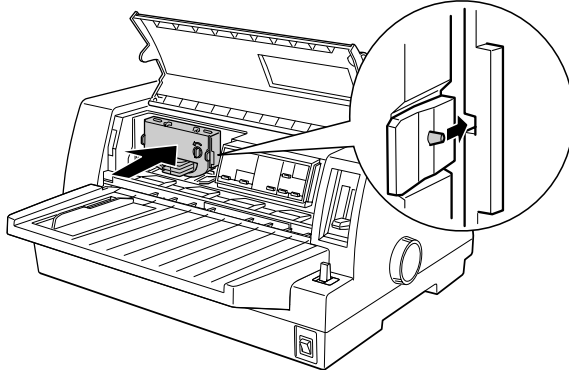

8. Turn the ribbon-tightening knob again to remove any slack in the ribbon and to make sure the ribbon moves freely.

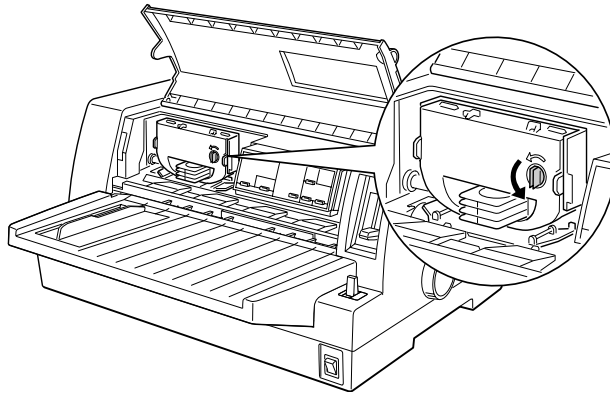

9. Close the printer cover.

**Note:**

*The printer pauses and cannot print when the printer cover is open.*

---

## ***Installing the Printer Software***

After you connect the printer to your computer, you need to install the software included on the EPSON printer software CD-ROM shipped with your printer.

Your printer software includes:

- ❑ **Printer driver**  
The printer driver is the software that runs, or “drives,” your printer. With it, you can make printer settings such as print quality, resolution, and paper size.
- ❑ **EPSON Status Monitor 3 (for Windows 98, 95, 2000 and NT 4.0)**  
The EPSON Status Monitor 3 notifies you of printer errors and displays printer status information.
- ❑ **EPSON Remote! (a DOS-based printer setup utility)**  
The EPSON Remote! utility allows you to easily change the printer’s default settings from the computer screen. See “Using the EPSON Remote! Utility” on page 3-19.

To install the printer software, see “Installing the printer software in Windows 98, 95, 2000, or NT 4.0” or “Installing the printer software in Windows 3.1 or NT 3.5x” in this section. If you are using DOS, see “For DOS programs” on page 1-16.

# Installing the printer software in Windows 98, 95, 2000, or NT 4.0

Follow the steps below to install the printer software in Windows 98, 95, 2000, or NT 4.0:

**Note:**

- ❑ *Installing the printer software for Windows 2000 or NT 4.0 may require administrator privileges. If you have problems, ask your administrator for more information.*
  - ❑ *If you wish to make a diskette version of the printer software on your CD-ROM, insert the CD and run the EPSETUP program. In the dialog box that appears, click the Driver disk creation utility button and follow the on-screen instructions.*
  - ❑ *If you are using the diskette version of the EPSON software, make a backup copy of the EPSON printer software disk or disks before you begin installation.*
  - ❑ *If the New Hardware Found screen or any other wizard appears when you turn on your computer, click CANCEL and follow the steps below.*
  - ❑ *If the Digital Signature Not Found screen appears, click Yes. If you click NO, you must reinstall the printer driver as described below.*
  - ❑ *Installation time varies depending on your computer.*
1. Make sure Windows 98, 95, 2000, or NT 4.0 is running and the printer is off.
  2. Insert the printer software CD-ROM in the CD-ROM drive. The Install dialog box appears. (If you are using diskettes, insert the diskette in a disk drive, then double-click the Drive icon and double-click the Setup.exe icon.)

3. Click Install to start the printer software installation.
4. Select your printer from the list, then follow the instructions on the screen.

When you install the printer driver on Windows 98, 95, 2000 or NT 4.0, EPSON Status Monitor 3 will also be installed.

For information on opening and using the software, see Chapter 3, "Using the Printer Software."

## ***Installing the printer software in Windows 3.1 or NT 3.5x***

Follow the steps below to install the printer software in Windows 3.1 or NT 3.5x systems.

### ***Note:***

*Installing the printer software on Windows NT 3.5x may require administrator privileges. If you have problems, ask your administrator for more information.*

1. Make sure Windows is running and the Program Manager window is open.
2. Insert the printer software CD-ROM shipped with your printer in the CD-ROM drive. (If you are using diskettes, insert Disk1 of your printer software in a disk drive.)



3. Choose RUN from the File menu. The Run dialog box appears. In the Command Line box, type D:SETUP. (Substitute the appropriate drive letter as necessary.) Then click OK.

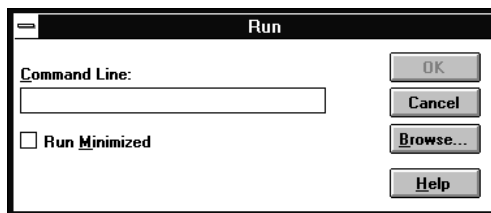

If you wish to make a diskette version of the printer software on your CD-ROM, type EPSETUP instead of SETUP. In the dialog box that appears, click the Driver disk creation utility button and follow the on-screen instructions.

4. Select your printer from the list.
5. The installation program begins copying the printer software files.
6. When the installation is complete, click OK to exit the installation program.

The installation program automatically selects the LQ-680/LQ-680Pro as the default printer for Windows applications. For information on opening and using the software, see Chapter 3, "Using the Printer Software."

## ***For DOS programs***

To control the printer from DOS application programs, you need to select the printer you are using or another available printer from the printer list of your application.

Choose the EPSON LQ-680/LQ-680Pro printer at the appropriate step in the setup or installation procedure of your DOS application program. If the list in your application does not include the LQ-680/LQ-680Pro printer, choose the first available printer from this list:

- LQ-670
- LQ-580/LQ-570e
- LQ-2070/LQ-2080
- LQ-2170/LQ-2180
- LQ-870/LQ-1170
- LQ-570/1070/570+/1070+
- DLQ-3000/DLQ-3000+
- DLQ-2000
- LQ-1060
- LQ-1050
- LQ-2550
- LQ-2500

***Note:***

*If your application does not list a suitable alternative, contact the software manufacturer to see if an update is available.*

## Chapter 2

# Paper Handling

---

2

Selecting a Paper Source . . . . .	2-2
Paper source and paper types . . . . .	2-3
Setting the paper release lever (LQ-680) . . . . .	2-4
Setting the Paper Source button (LQ-680Pro) . . . . .	2-5
Adjusting the Paper Thickness Lever . . . . .	2-6
Using Continuous Paper . . . . .	2-8
Positioning your continuous paper supply . . . . .	2-8
Loading continuous paper with the tractor . . . . .	2-9
Using the tear-off function . . . . .	2-14
Removing continuous paper . . . . .	2-17
Using Continuous Multipart Forms . . . . .	2-17
Using Overlapping Multipart Forms (LQ-680Pro) . . . . .	2-18
Using Labels . . . . .	2-19
Using Single Sheets . . . . .	2-20
Using Single-Sheet Multipart Forms . . . . .	2-23
Using Envelopes . . . . .	2-24
Using Postcards . . . . .	2-25
Switching Between Continuous Paper and Single Sheets . . . . .	2-26
Switching to single sheets . . . . .	2-26
Switching to continuous paper . . . . .	2-28
Using Micro Adjust . . . . .	2-28
Adjusting the loading position . . . . .	2-28
Adjusting the tear-off position . . . . .	2-31
Adjusting the printing position . . . . .	2-32

Your printer can print on a wide variety of paper types, including single sheets, continuous paper, multipart forms, labels, envelopes, postcards, and roll paper. This chapter explains how to use these paper types with your printer.

**Note:**

*See Appendix C for detailed specifications on the paper types the printer can use.*

---

## **Selecting a Paper Source**

Your printer can accommodate a variety of paper types through four paper sources: paper guide, tractor, optional cut-sheet feeder, or optional roll paper holder. The paper source you should select depends on the type of paper you want to use. See “Paper source and paper types” on page 2-3.

*For LQ-680 users:*

To select a paper source, use the paper release lever. See “Setting the paper release lever (LQ-680)” on page 2-4.

*For LQ-680Pro users:*

To select a paper source, use the Paper Source button on the control panel. See “Setting the Paper Source button (LQ-680Pro)” on page 2-5.

## Paper source and paper types

The table below shows which paper source to use for each paper type.

Paper type	Paper source			
	Tractor	Paper guide	Optional cut-sheet feeder	Optional roll paper holder**
Continuous paper	○	-	-	-
Continuous multipart forms	○	-	-	-
Labels	○	-	-	-
Single sheets	-	○	○	-
Single-sheet multipart forms	-	○	○* (bin 1 only)	-
Envelopes	-	○	○ (bin 1 only)	-
Postcards	-	○	○ (bin 1 only)	-
Roll paper	-	-	-	○



○ : You can use this paper type with this paper source.

- : You cannot use this paper type with this paper source.

\* You can use only carbonless single-sheet multipart forms that are glued at the top of the forms.

\*\* The optional roll paper holder is not available in some countries.

## Setting the paper release lever (LQ-680)

Set the paper release lever to select the paper-feeding method you want the printer to use. The paper release lever has two positions:  for tractor feeding and  for single-sheet feeding, as explained below.

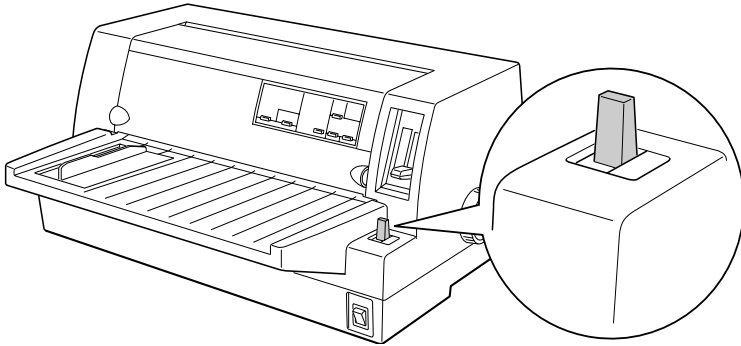

Single-sheet feeding position – to use the paper guide, the optional cut-sheet feeder, or the optional roll paper holder.



Tractor feeding position – to use the tractor.

## Setting the Paper Source button (LQ-680Pro)

Set the Paper Source button on the control panel to select the paper source you want the printer to use. There are three settings: Tractor for tractor feeding, Manual/CSF Bin1 for single-sheet feeding including the cut-sheet feeder bin 1, and Manual/CSF BIN2 for single-sheet feeding including cut-sheet feeder bin 2, as explained below.

2

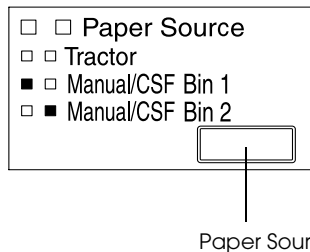

Tractor	Tractor feeding position – to use the tractor.
Manual/CSF Bin1	Single-sheet feeding position 1 – to use the paper guide, the optional cut-sheet feeder bin 1, or the optional roll paper holder.
Manual/CSF Bin2	Single-sheet feeding position 2 – to use the paper guide, the optional cut-sheet feeder bin 2, or the optional roll paper holder.

---

## Adjusting the Paper Thickness Lever

You need to set the paper thickness lever to match the thickness of your paper.

There are nine lever positions, from -1 to 7. The Auto position is also available on the LQ-680Pro.

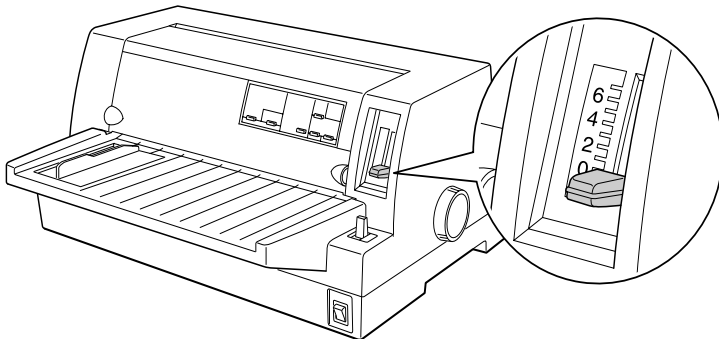

*For LQ-680 users:*

Set the paper thickness lever manually to the appropriate position from -1 to 7, as described in the table below.

*For LQ-680Pro users:*

We recommend using the Auto position for all types of paper. When the Auto position is selected, the printer automatically adjusts itself to match the thickness each time it loads new paper, but your printing time may be slowed. If you use the same type of paper every time, you may want to set the paper thickness lever to the appropriate manual position as described in the table below to speed-up printing.



The following table provides guidelines for selecting the appropriate lever position for the type of paper you are using.

Paper type	Paper thickness lever position	
Ordinary paper (single sheets or continuous paper)	-1 or 0	Auto**
Multipart forms (single sheets or continuous paper)		
2 parts (original plus + 1 copy)	1	
3 parts (original plus + 2 copies)	2	
4 parts (original plus + 3 copies)	3	
5 parts (original plus + 4 copies)	5	
6 parts (original plus + 5 copies)	7	
Labels	2	
Postcards	2	
Envelopes*	2 to 6	

\* For thin envelopes, such as airmail envelopes, select position 2 or 3; for regular envelopes, select position 4; for thick envelopes, select position 4, 5, or 6.

\*\* LQ-680Pro only.



**Caution:**

*If you set the paper thickness lever to 1 or higher, be sure to set the lever back to the 0 (or Auto position for LQ-680Pro) before you print on ordinary paper again.*

---

## Using Continuous Paper

You can load continuous paper from the built-in tractor unit located on the back of the printer.

**Note:**

See *Appendix C* for detailed specifications on continuous paper.

## Positioning your continuous paper supply

When you load continuous paper, make sure you align your paper supply with the tractor so the paper feeds smoothly into the printer, as shown below.

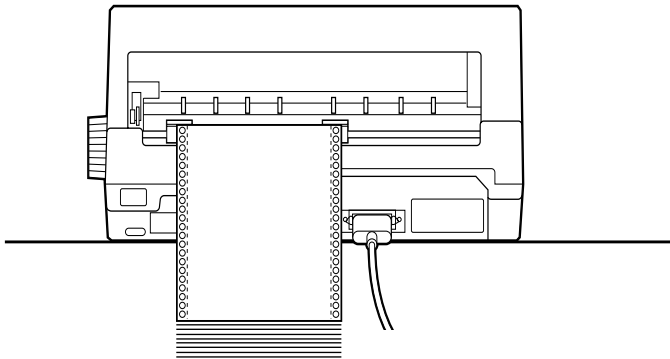
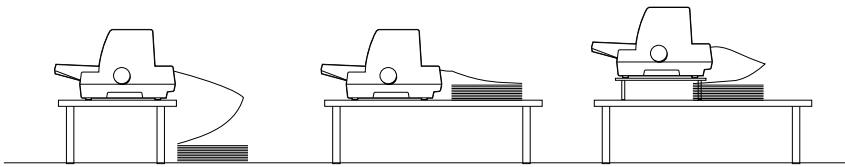

## Loading continuous paper with the tractor

1. Make sure the printer is turned off.
2. *For LQ-680 users:*  
Select tractor feeding with the paper release lever, and make sure the paper thickness lever is set to 0 if you are using ordinary continuous paper.

*For LQ-680Pro users:*

Select tractor feeding with the Paper Source button, and make sure the paper thickness lever is set to Auto or 0 if you are using ordinary continuous paper.

3. Slide the edge guide out as far as it will go.

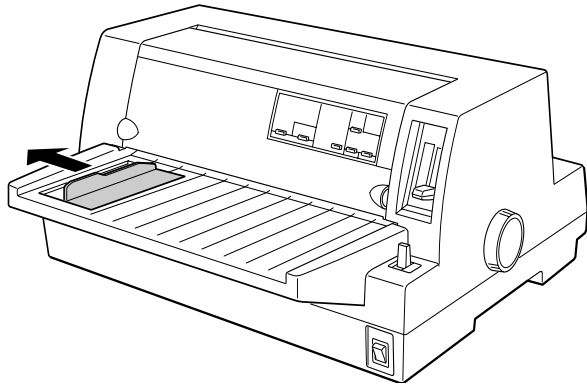

4. Release the sprocket lock levers by pushing them up.

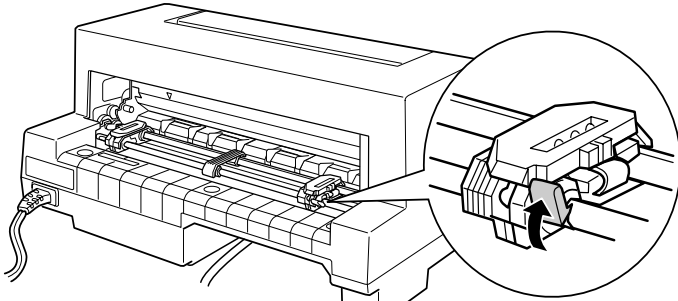

5. Facing the back of the printer, position the left sprocket unit so that the sprocket pins are to the left of the "0" on the scale and the arrow mark on the printer. Then push down the lock lever to lock the sprocket in place.

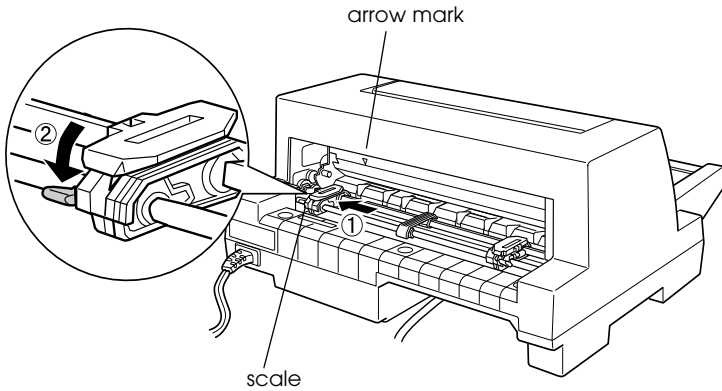

**Note:**

*Printing starts at the arrow mark on the printer and the "0" mark on the scale. The unprintable area is to the left of the arrow mark and the "0".*

- Slide the right sprocket unit to roughly match the width of your paper, but do not lock it.

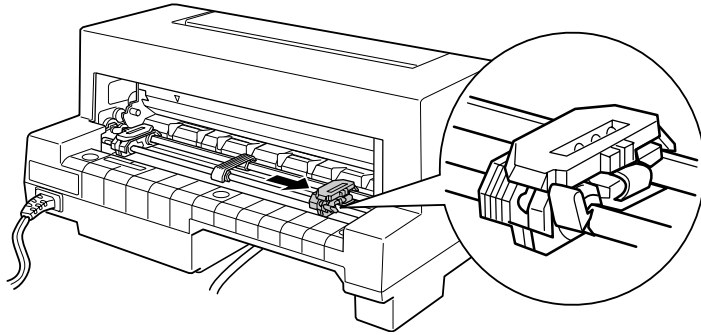

2

- Slide the paper support midway between the two sprocket units.

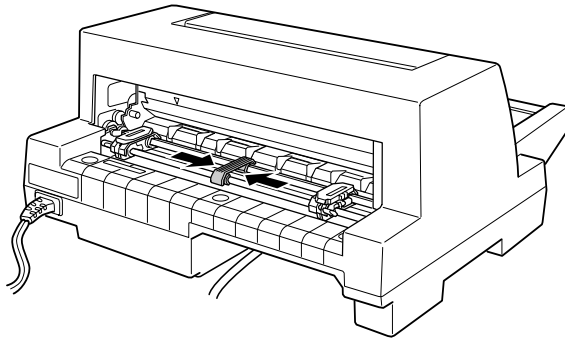

8. Open the sprocket covers.

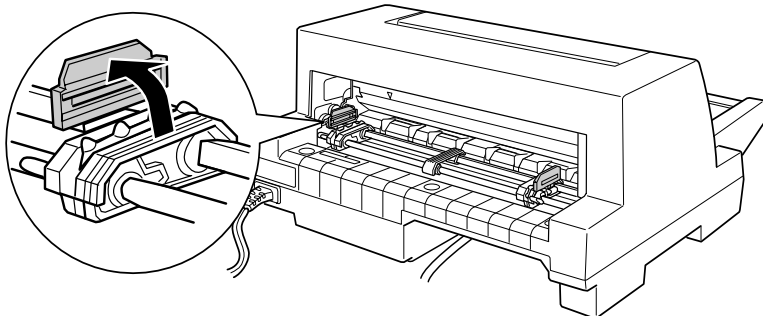

9. Fit the first three holes of the continuous paper over the sprocket pins on both sides. Be sure to load your paper printable side up.

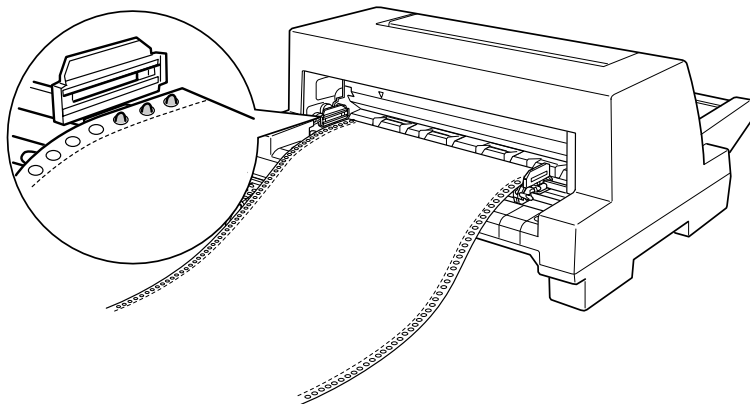

**Caution:**

*Make sure the first sheet of your continuous paper has a clean, straight edge so that it can feed smoothly into the printer.*

10. Close the sprocket covers. If necessary, unlock and reposition the left sprocket unit so that the perforation aligns with the arrow mark on the printer. Then lock the sprocket in place.

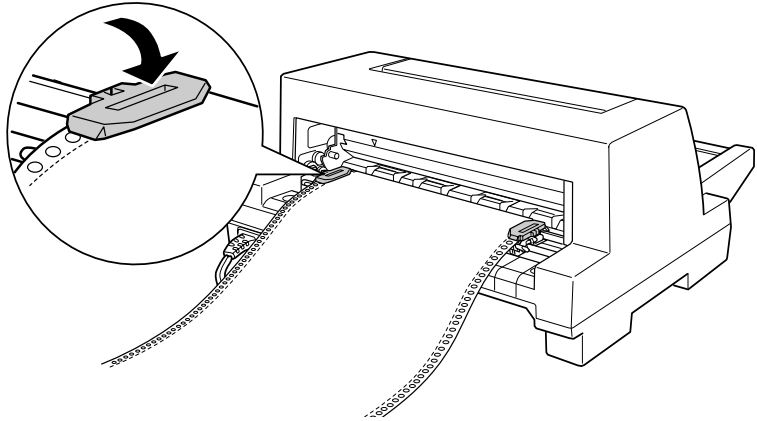

11. Slide the right sprocket unit to remove any slack in the paper. Then push down the sprocket lock lever to lock the sprocket in place.

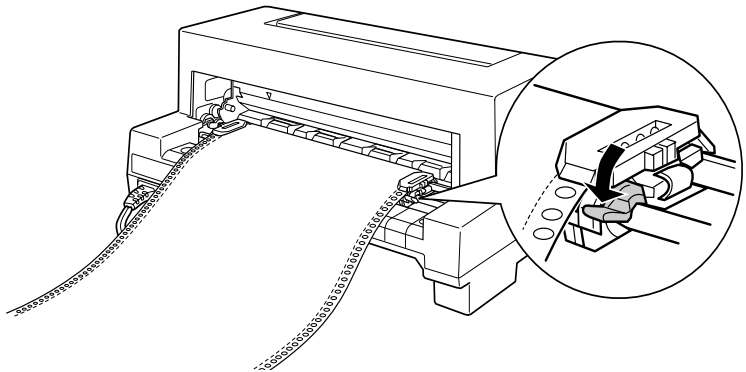

12. Turn on the printer. When the printer receives data, it automatically loads the paper before printing.

When using continuous paper, you can use the tear-off function to tear off printed pages not wasting any blank pages next to the printed pages. For more information, see the next section.

**Note:**

- ❑ *You can advance the paper to the loading position by pressing the Load/Eject button before the printer receives data.*
- ❑ *Always make sure there is at least one more sheet than required, because continuous paper may not feed properly if it is not fed through the sprocket.*



**Caution:**

*Use the knob on the right side of the printer only to clear paper jams when the printer is off. Otherwise, you may damage the printer or cause it to lose the top-of-form position.*

## **Using the tear-off function**

After you have finished printing, you can use the tear-off function to advance continuous paper on the tractor to the tear-off edge of the printer. You can then easily tear off printed sheets. When you resume printing, the printer automatically feeds paper back to the loading position so you can save paper that would normally be lost between documents.

You can use the tear-off function in two ways: by pressing the button on the control panel, or by using the control panel's default-setting mode or the EPSON Remote! utility to select auto tear-off. (See "About Your Printer's Default Settings" on page 4-3 for information on the printer's default-setting mode.)



If the perforation between pages is not aligned with the tear-off edge, you can adjust the tear-off position using the micro-adjust feature as described later in this chapter.



**Caution:**

*Never use the tear-off function to feed labels backwards; they may come off their backing and jam the printer.*

### Using the Tear Off button

You can use the Tear Off button (the Tear Off/Bin button on the LQ-680 or the Tear Off/Special Paper button on the LQ-680Pro) to advance continuous paper to the tear-off position by following the steps below:

1. Make sure printing has finished. Then press the Tear Off button until the two lights on the control panel start flashing. The printer advances the paper to the tear-off edge.

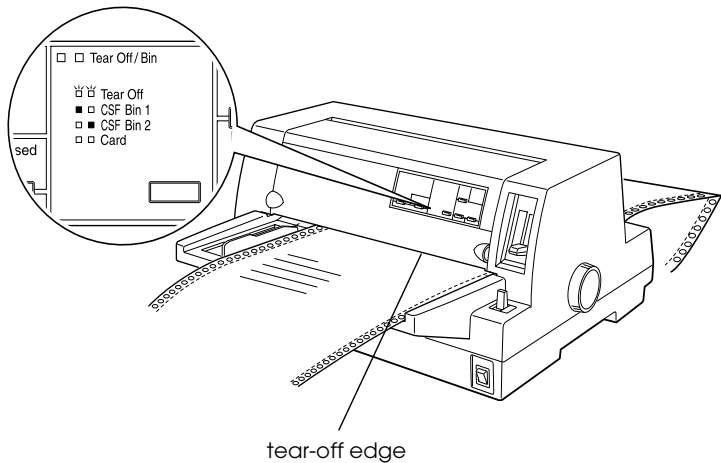

2. Tear off all printed pages at the tear-off edge. If the perforation is not aligned with the tear-off edge, adjust the tear-off position using the micro-adjust feature. See “Adjusting the tear-off position” later in this chapter.

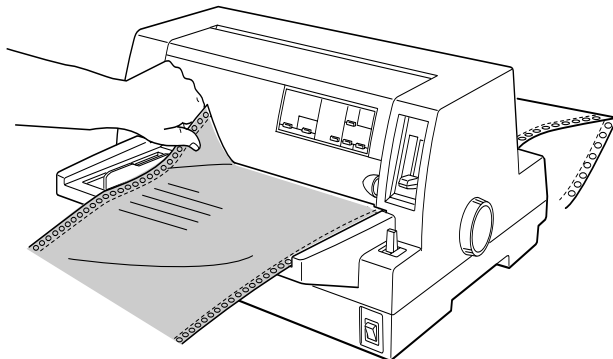

3. When you resume printing, the printer feeds the paper back to the top-of-form position and begins printing. (You can also manually feed the paper back to the top-of-form position by pressing the same button used to advance the paper.)

### ***Using auto tear-off mode***

When you turn on the auto tear-off function in the printer's default-setting mode or the EPSON Remote! utility, the printer advances continuous paper to the tear-off position when you finish printing.

The printer advances paper to the tear-off position only when it receives a full page of data or a form-feed command and then receives no more data for three seconds.

For instructions on how to activate the auto tear-off function, see “About Your Printer’s Default Settings” on page 4-3 or open the EPSON Remote! utility as described in Chapter 3 and follow the on-screen instructions. While using the default-setting mode or the utility, also make sure the page length is set correctly for your continuous paper.

After the paper has been advanced, tear off all printed pages and resume printing as described in “Using the Tear Off button” earlier in this chapter.

You can leave the auto tear-off mode on even when you are using single sheets. The mode is disabled while you are using single sheets.

## ***Removing continuous paper***

1. After you finish printing, tear-off all printed pages using the tear-off function.
2. Press the Load/Eject button to feed the continuous paper backward out of the printer and into the standby position.
3. To completely remove continuous paper from the printer, open the sprocket covers. Remove the paper from the tractor unit, and then close the sprocket covers.

---

## ***Using Continuous Multipart Forms***

Your printer can use continuous multipart forms with up to six parts including the original. You can use carbonless or carbon-backed multipart forms.



***Caution:***

*Do not use carbon-interleaved multipart forms.*

Before printing, set the paper thickness lever to the correct position for your multipart forms. LQ-680 users should set the lever as described in the table on page 2-7. LQ-680Pro users should make sure the lever is set to the Auto position.

You can load continuous multipart forms in the same way as you load ordinary continuous paper. For instructions, see “Using Continuous Paper” earlier in this chapter.



**Caution:**

*When printing on multipart forms, make sure that your software settings keep the printing entirely within the printable area of the forms. Printing on the edge of a multipart form can damage the print head. For information about the printable area, see the paper specifications in Appendix C.*

---

## **Using Overlapping Multipart Forms (LQ-680Pro)**

LQ-680Pro users can print on overlapping multipart forms backed with continuous paper. The page length of the multipart forms is longer than that of the backing continuous paper. So when extended, one page's multipart forms overlap the next page's multipart forms. The thickness of this overlapping area is thicker than the printable area.

Before printing, set the paper thickness lever to the Auto position. Also turn on both the overlapping-forms and the skip-over-perforation settings using the default setting mode. See “Adjusting the Paper Thickness Lever” earlier in this chapter and “Changing default settings” on page 4-9 for more information.

You can load continuous multipart forms in the same way as you load ordinary continuous paper. For instructions, see “Using Continuous Paper” earlier in this chapter.

**Caution:**

- ❑ *When printing on overlapping multipart forms, make sure that your software settings keep the printing entirely within the printable area of the forms. Printing on the edge of a multipart form can damage the print head. For information about the printable area, see the paper specifications in Appendix C.*
- ❑ *Never feed overlapping multipart forms backward with the Load/Eject or Tear Off/Special Paper buttons. Doing so may cause paper jams or damage to the printer.*
- ❑ *To remove overlapping multipart forms from the paper path after you finish printing, first tear off the paper at a point before the paper slot. Then use the LF/FF button to advance the remaining paper out of the printer.*

---

## Using Labels

When selecting labels for printing, always choose labels mounted on continuous backing sheets with sprocket holes for use with a tractor. Do not use labels on shiny single-sheet backing, because the backing sheet tends to slip and may not feed properly.

Labels are loaded in the same way as you load ordinary continuous paper, except for the paper thickness lever setting. LQ-680 users should set the lever to 2. LQ-680Pro users are recommended to use the Auto setting, or set it manually to 2 for faster throughput. For instructions on loading, see “Using Continuous Paper” earlier in this chapter. For instructions on paper thickness lever setting, see “Adjusting the Paper Thickness Lever” earlier in this chapter.

**Caution:**

- ❑ *When printing on labels, make sure that your software settings keep the printing entirely within the printable area. Printing on the edge of a label can damage the print head. For information about the printable area, see the paper specifications in Appendix C.*
- ❑ *Never feed labels backward with the Load/Eject, Tear Off/Bin (LQ-680), or Tear Off/Special Paper (LQ-680Pro) buttons. Labels can easily peel off their backing and jam the printer.*
- ❑ *To remove labels from the paper path after you finish printing, first tear off the labels at a point before the paper slot. Then use the LF/FF button to advance the remaining labels out of the printer.*
- ❑ *Because labels are especially sensitive to temperature and humidity, use them only under normal operating conditions.*
- ❑ *Do not leave labels loaded in the printer between print jobs; they tend to curl and may come off their backing and jam the printer when you resume printing.*

---

## Using Single Sheets

You can load one sheet of paper at a time into the paper guide at the front of the printer, or you can load a stack of paper in the optional cut-sheet feeder. (See Appendix A for more information on the optional cut-sheet feeder.)

**Note:**

- ❑ *See Appendix C for detailed single-sheet paper specifications.*
- ❑ *If you load long paper (for example, legal size paper), leave enough space at the back of the printer so that the paper is not obstructed.*

Follow these steps to load single sheets from the paper guide:

1. Make sure that the printer is off and the paper guide is attached as described in Chapter 1. Then close the sprocket covers and push down the sprocket lock levers to lock the sprocket units in place.

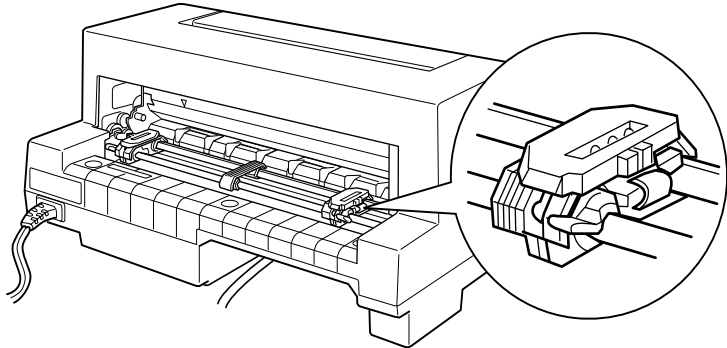

2. *For LQ-680 users:*  
Select single-sheet feeding with the paper release lever as described in “Selecting a Paper Source” on page 2-2. Also make sure the paper thickness lever is set to 0 if you are using ordinary single-sheet paper.

*For LQ-680Pro users:*

Select single-sheet feeding with the Paper Source button as described in “Selecting a Paper Source” on page 2-2. Also make sure the paper thickness lever is set to Auto or 0 if you are using ordinary single-sheet paper.

3. Turn on the printer.

- Slide the edge guide until it rests against the guide mark, as shown below.

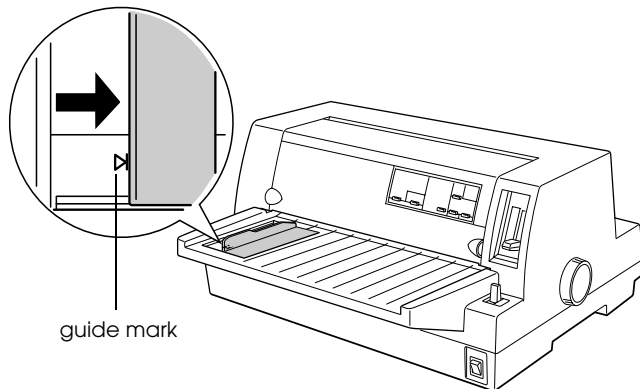

- Insert a sheet of paper, following the edge guide, until it meets resistance. Be sure to load your paper printable side up and top edge first.

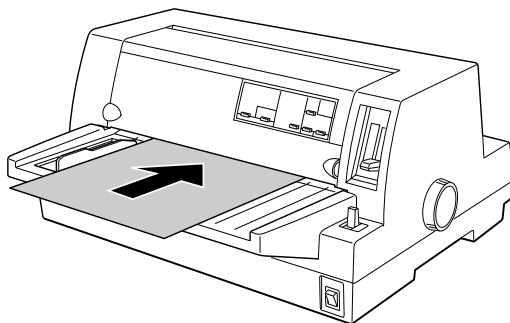

After a few seconds, the printer automatically advances the paper to the loading position. The printer is ready to accept data from your computer and print.

**Note:**

*If the rollers rotate but the printer does not load the paper, remove the paper completely and reinsert it.*



After printing a sheet, the printer ejects the printed sheet onto the paper guide. If you are printing a multiple-page document, remove the printed sheet and insert a new sheet into the paper guide. The printer automatically advances the paper and resumes printing.

**Note:**

*If the printer does not eject the printed sheet, press the Load/Eject button.*



**Caution:**

*Use the knob on the right side of the printer only to clear paper jams when the printer is off. Otherwise, you may damage the printer.*

---

## **Using Single-Sheet Multipart Forms**

Your printer can use single-sheet multipart forms with up to six parts including the original. You can use carbonless multipart forms, or carbon-backed multipart forms using the paper guide.



**Caution:**

*Do not use carbon-interleaved multipart forms.*

Before printing, set the paper thickness lever to the correct position for your multipart forms as described in the table on page 2-7, or to the Auto position (LQ-680Pro only).

You can load single-sheet multipart forms in the same way as you load ordinary single sheet. For instructions, see “Using Single Sheets” earlier in this chapter or Appendix A, “Loading paper from the cut-sheet feeder.”

**Caution:**

- ❑ *When printing on multipart forms, make sure that your software settings keep the printing entirely within the printable area of the forms. Printing on the edge of a multipart form can damage the print head. For information about the printable area, see the paper specifications in Appendix A.*
  
- ❑ *Load single-sheet multipart forms glued at the side of the form only from the paper guide, not from the optional cut-sheet feeder.*

---

## **Using Envelopes**

You can print on a variety of envelopes, loading them in the same way as you load single sheets: from the paper guide or with the optional cut-sheet feeder. For information on loading envelopes, read this section and see “Using Single Sheets” earlier in this chapter or Appendix A, “Loading paper from the cut-sheet feeder.”

*For LQ-680 users:*

Before printing, set the paper thickness lever to the correct position for your envelopes as described in the table on page 2-7.

*For LQ-680Pro users:*

Before printing, make sure the paper thickness lever is set to Auto or the correct position for your envelopes as described in the table on page 2-7. Then select Envelope by pressing the Tear Off/Special Paper button.

Load envelopes face up, flap-edge first.

**Caution:**

- ❑ *When printing on envelopes, make sure that your software settings keep the printing entirely within the printable area. Printing on the edge of an envelope can damage the print head. For information on the printable area, see the paper specifications in Appendix C.*
  
- ❑ *Use envelopes only under normal operating conditions.*

---

## **Using Postcards**

You can print on a variety of postcards, loading them in the same way as you load single sheets: from the paper guide or with the optional cut-sheet feeder. For instructions on loading single sheets, see “Using Single Sheets” on page 2-20 or “Loading paper from the cut-sheet feeder” on page A-6.

*For LQ-680 users:*

Before printing, set the paper thickness lever to 2. Then select Card by pressing the Tear Off/Bin button on the control panel.

*For LQ-680Pro users:*

Before printing, make sure the paper thickness lever is set to Auto or 2. Then select Card by pressing the Tear Off/Special Paper button on the control panel.

Load postcards printable side up, top edge first.



**Caution:**

- ❑ *Card mode is available only when the paper thickness lever is set to Auto or 2 or higher on the scale.*
- ❑ *When printing on postcards, make sure that your software settings keep the printing entirely within the printable area. Printing on the edge of a postcard can damage the print head. For information about the printable area, see the paper specifications in Appendix C.*
- ❑ *Use postcards only under normal operating conditions.*

---

## **Switching Between Continuous Paper and Single Sheets**

When using the tractor, you can easily switch between continuous paper and single sheets (including envelopes or postcards) without removing the continuous paper from the tractor.

### **Switching to single sheets**

To switch from continuous paper to single sheets, follow the steps below.



**Caution:**

*When using continuous paper with labels, never follow the steps to feed labels backward. Labels can easily peel off their backing and jam the printer. For information on removing labels from the paper path, see “Using Labels” earlier this chapter.*

1. When you have finished printing on continuous paper, press the Tear Off/Bin button (LQ-680) or the Tear Off/Special Paper button (LQ-680Pro) to advance the paper to the tear-off position. (If you selected auto tear-off in the printer's default-setting mode or the EPSON Remote! utility, the printer advances the paper perforation to the tear-off position automatically.)
2. Tear off the printed pages.



**Caution:**

*Always tear off paper before feeding it backwards; feeding too many sheets backwards can cause a paper jam.*

3. Press the Load/Eject button to feed the continuous paper back to the standby position. The paper is still attached to the tractor, but no longer in the paper path.
4. Select single-sheet feeding with the paper release lever (LQ-680) or with the Paper Source button (LQ-680Pro) as described in "Paper source and paper types" on page 2-3.

Now you can load single sheets from the paper guide. For instructions, see "Using Single Sheets" on page 2-20.

## **Switching to continuous paper**

To switch from single sheets to continuous paper, follow the steps below.

1. If necessary, press the **LOAD/EJECT** button to eject the last printed single sheet.
2. Make sure continuous paper is loaded in the printer as described in “Loading continuous paper with the tractor” on page 2-9.
3. Select tractor feeding with the paper release lever (LQ-680) or with the **PAPER SOURCE** button (LQ-680Pro) as described in “Paper source and paper types” on page 2-3.

The printer automatically advances the continuous paper from the standby position to the loading position when it receives data.

---

## **Using Micro Adjust**

The micro-adjust feature allows you to move paper forward or backward in 1/180-inch increments. You can use this feature to adjust the loading, printing, and tear-off positions.

## **Adjusting the loading position**

The loading position is the position of the paper after the printer loads it. If your printing appears too high or low on the page, you can change the loading position with the micro-adjust feature as follows:

**Note:**

*Top margin settings made in some application software override adjustments you make to the loading position with the micro adjust feature. If necessary, adjust the loading position in your software.*

1. Make sure the printer is turned on. If necessary, lift up the printer cover so you can see the paper position.
2. Load either continuous or single-sheet paper. (Press the Load/Eject button to load continuous paper from the tractor or a single sheet from the optional cut-sheet feeder.)
3. Hold down the Pause button for about three seconds. The Pause light starts flashing and the printer enters the micro-adjust mode.
4. Press the LF/FF [↓] button to move the paper toward the front of the printer, or press the Load/Eject [↑] button to move the paper toward the rear. The new loading position is set to the position where you release the buttons.

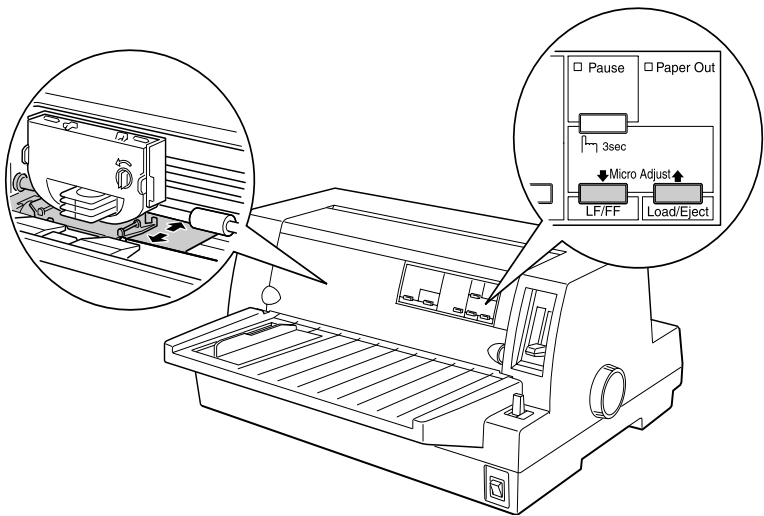

**Note:**

- ❑ Pressing the LF/FF [↓] button moves the loading position toward the top of the page when loading a sheet from the front (from the paper guide). Pressing the LF/FF [↓] button moves the loading position toward the bottom of the page when loading a sheet from the rear (from the cut-sheet feeders or the tractor).
- ❑ The printer has a minimum and a maximum loading position. If you try to adjust the loading position beyond these limits, the printer beeps and stops moving the paper.
- ❑ When the paper reaches the factory-set loading position, the printer beeps and paper feeding pauses briefly. Use the factory setting as a reference point when adjusting the loading position.
- ❑ If you want to eliminate the top margin and print at the very top of the page, adjust the loading position so that the top of the paper lines up with the raised line on the ribbon mask, as shown below.

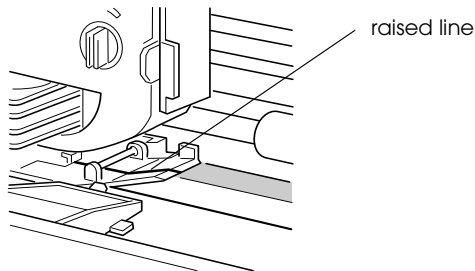

5. After you set the loading position, press the Pause button to turn off micro-adjust mode.

For both single-sheet and continuous paper, your loading position setting remains in effect until you change it, even if you turn off the printer.



## Adjusting the tear-off position

If your continuous paper perforation is not aligned with the tear-off edge, you can use the micro-adjust feature to move the perforation to the tear-off position as follows:

1. Make sure both Tear Off lights are flashing (the paper is at the current tear-off position). You may need to press the Tear Off button. (See “Using the Tear Off button” on page 2-15 for more information.)
2. Hold down the Pause button for about three seconds. The Pause light begins flashing and the printer enters the micro-adjust mode.
3. Press the LF/FF [↓] button to feed paper forward, or press the Load/Eject [↑] button to feed paper backward, until the paper perforation is aligned with the tear-off edge.

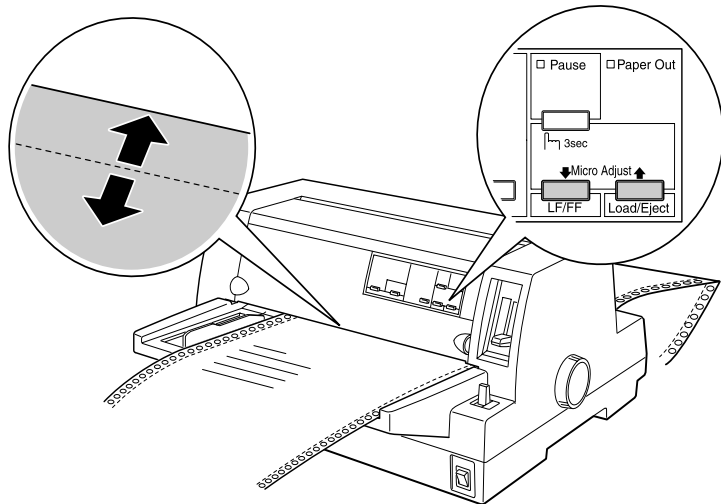

### Note:

The printer has a minimum and a maximum tear-off position. If you try to adjust the tear-off position beyond these limits, the printer beeps and stops moving the paper.

4. Tear off the printed pages.
5. Press the **PAUSE** button to turn off micro-adjust mode.

When you resume printing, the printer automatically feeds the paper back to the top-of-form position and begins printing. Your tear-off position setting remains in effect until you change it, even if you turn off the printer.

## ***Adjusting the printing position***

The printing position is the position on the page where the print head actually prints during a print job. You can change the current vertical printing position temporarily by using the micro-adjust feature as described in the steps below.

### ***Note:***

*Your printing position setting is in effect only until the next time you load paper or turn off the printer.*

1. Make sure that the printer is not printing. If it is, press the **PAUSE** button to stop printing.
2. Hold down the **PAUSE** button for about three seconds. The **PAUSE** light begins flashing and the printer enters the micro-adjust mode.
3. If necessary, open the printer cover to check the printing position, and press the **LF/FF** [**↓**] button to feed paper forward or the **Load/Eject** [**▲**] button to feed paper backward.
4. When your paper is positioned correctly, press the **PAUSE** button to turn off micro-adjust mode and resume printing.

## Chapter 3

# Using the Printer Software

---

About Your Printer Software . . . . .	3-2
Using the Printer Driver With Windows 98 or 95 . . . . .	3-3
Accessing the printer driver from Windows applications . . . . .	3-3
Accessing the printer driver from the Start menu . . . . .	3-5
Changing the printer driver settings . . . . .	3-5
Using the Printer Driver With Windows 3.1 . . . . .	3-6
Accessing the printer driver from Windows applications . . . . .	3-6
Accessing the printer driver from the Control Panel . . . . .	3-8
Changing the Printer driver settings . . . . .	3-8
Using the Printer Driver With Windows 2000 and NT 4.0 . . . . .	3-9
Accessing the printer driver from Windows applications . . . . .	3-9
Accessing the printer driver from the Start menu . . . . .	3-11
Changing the printer driver settings . . . . .	3-12
Using the Printer Driver With Windows NT 3.5x . . . . .	3-13
Accessing the printer driver from Windows applications . . . . .	3-13
Accessing the printer driver from the Control Panel . . . . .	3-15
Changing the Printer driver settings . . . . .	3-16
Printer Driver Settings Overview . . . . .	3-17
Using the EPSON Remote! Utility . . . . .	3-19
Installing EPSON Remote! . . . . .	3-19
Accessing EPSON Remote! . . . . .	3-19
Using the EPSON Status Monitor 3 Utility . . . . .	3-20
Setting up EPSON Status Monitor 3 . . . . .	3-20
Accessing EPSON Status Monitor 3 . . . . .	3-22



---

## About Your Printer Software

The EPSON printer software that comes with your printer includes the printer driver software, the EPSON Remote! utility, and the EPSON Status Monitor 3 utility for Windows 98, 95, 2000 and NT 4.0.

A printer driver is software that allows your computer to control the printer. You need to install the printer driver so your Windows software applications can take full advantage of the printer's capabilities.

**Note:**

*Before proceeding, make sure you have installed the printer driver on your PC as described in Chapter 1.*

EPSON Remote! is a DOS-based printer setup utility that allows you to easily change the printer's default settings from the computer screen. To use the EPSON Remote! utility with DOS, see "Using the EPSON Remote! Utility" on page 3-19.

The EPSON Status Monitor 3 utility program is available for Windows 98, 95, 2000 and NT 4.0. It allows you to monitor the status of your printer, alerts you when errors occur, and provides you with troubleshooting tips. To use the Status Monitor, see "Accessing EPSON Status Monitor 3" on page 3-22.

For an overview of the available settings, see "Printer Driver Settings Overview" on page 3-17.

To access the printer driver, see the appropriate page below, depending on your Windows version.

Windows 98 and 95 . . . . .	page 3-3
Windows 3.1 . . . . .	page 3-6
Windows 2000 and NT 4.0 . . . . .	page 3-9
Windows NT 3.5x . . . . .	page 3-13

---

## **Using the Printer Driver With Windows 98 or 95**

You can access the printer driver from your Windows applications or from the Start menu. When you access the printer driver from a Windows application, any settings you make apply only to the application you are using. See “Accessing the printer driver from Windows applications” below. When you access the printer driver from the Start menu, the printer driver settings you make apply to all your applications. See “Accessing the printer driver from the Start menu” on page 3-5. To check and change printer driver settings, see “Changing the printer driver settings” on page 3-5.

**Note:**

*While many Windows applications override the settings made with the printer driver, some do not, so you must verify that the printer driver settings match your requirements.*

### **Accessing the printer driver from Windows applications**

To access the printer driver from a Windows application, follow the steps on the next page.

**Note:**

*The steps on the next page provide general guidelines on accessing the printer driver. How you access the printer driver may differ depending on your application. See your application manual for details.*

1. Select Print Setup or Print from the File menu of your application software. The Print or Print Setup dialog box appears.

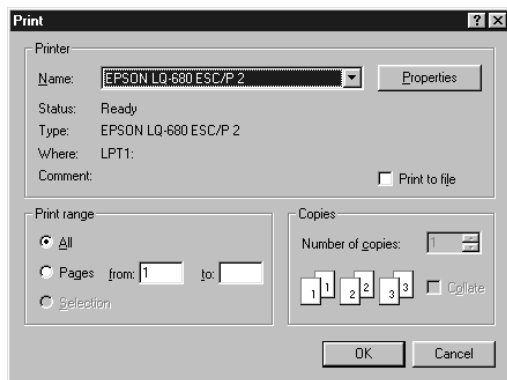

2. Make sure that your printer is selected and then click Printer, Setup, Properties, or Options. (You may need to click a combination of these buttons.) The Properties window appears, and you see the Paper, Graphics, and Device Options menu. These menus contain the printer driver settings.

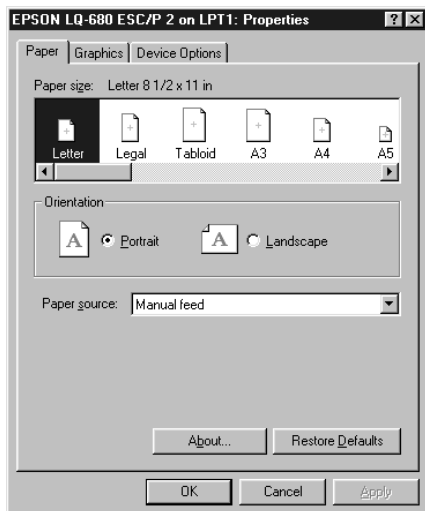

3. To view a menu, click the corresponding tab at the top of the window. See “Changing the printer driver settings” below to change the settings.

## ***Accessing the printer driver from the Start menu***

To access the printer driver from the Start menu, follow these steps:

1. Click the Start button, and then point to Settings.
2. Click Printers.
3. Right-click your printer icon, and click Properties. The screen displays the Properties window, which contains the Paper, Graphics, Device Options, and Utility menus. These menus display the printer driver settings.
4. To view a menu, click the corresponding tab at the top of the window. See the next section to change the settings.

## ***Changing the printer driver settings***

Your printer driver has four menus: Paper, Graphics, Device Options, and Utility. For an overview of the available settings, see “Printer Driver Settings Overview” on page 3-17. You can also view online help by right-clicking items in the driver and selecting What’s this?.

When you finish making printer driver settings, click OK to apply the settings, or click Restore Defaults to return the settings to their default values.

Once you’ve checked your printer driver settings and made any necessary changes, you are ready to print.

---

## **Using the Printer Driver With Windows 3.1**

You can access the printer driver from your Windows applications or from the Control Panel. When you access the printer driver from a Windows application, any settings you make apply only to the application you are using. See “Accessing the printer driver from Windows applications” below. When you access the printer driver from the Control Panel, the printer driver settings you make apply to all your applications. See “Accessing the printer driver from the Control Panel” on page 3-8. To check and change printer driver settings, see “Changing the Printer driver settings” on page 3-8.

**Note:**

*While many Windows applications override the settings made with the printer driver, some do not, so you must verify that the printer driver settings match your requirements.*

### **Accessing the printer driver from Windows applications**

To access the printer driver from a Windows application, follow the steps on the next page.

**Note:**

*The steps on the next page provide general guidelines on accessing the printer driver. How you access the printer driver may differ depending on your application. See your application manual for details.*



1. Select Print Setup or Print from the File menu of your application software. The Print or Print Setup dialog box appears. See “Changing the Printer driver settings” on page 3-8 for detailed information about the settings in this dialog box.

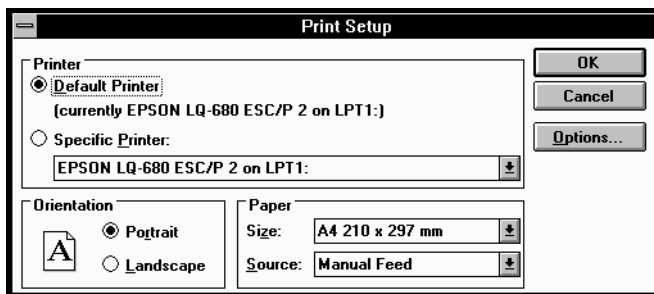

2. Make sure that your printer is selected and then click Printer, Setup, or Options. (You may need to click a combination of these buttons.) The Options dialog box appears. See “Changing the Printer driver settings” on page 3-8 to change the settings.

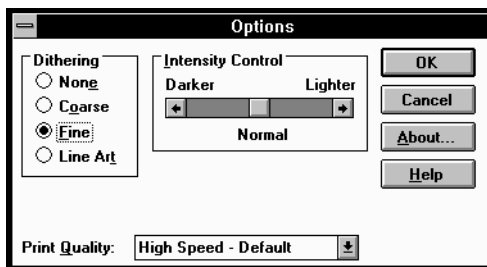

## ***Accessing the printer driver from the Control Panel***

To access the printer driver from the Control Panel, follow these steps:

1. In the Main window, double-click the Control Panel icon.
2. Double-click the Printers icon. The Printers dialog box appears.
3. Make sure your printer is highlighted, then click Setup. The Print Setup dialog box appears. To access more settings, you may need to click Options. See the next section to change the settings.

## ***Changing the Printer driver settings***

You can change printer driver settings in the Print (or Print Setup) dialog box and the Options dialog box. For an overview of the available settings, see “Printer Driver Settings Overview” on page 3-17.

When you finish making your printer driver settings, click OK to apply the settings, or click CANCEL to cancel your changes.

Once you’ve checked your printer driver settings and changed them if necessary, you are ready to print.

---

## Using the Printer Driver With Windows 2000 and NT 4.0

You can access the printer driver from your Windows applications or from the Start menu. When you access the printer driver from a Windows application, any settings you make apply only to the application you are using. See “Accessing the printer driver from Windows applications” below. When you access the printer driver from the Start menu, the printer driver settings you make apply to all your applications. See “Accessing the printer driver from the Start menu” on page 3-11. To check and change printer driver settings, see “Changing the printer driver settings” on page 3-12.

**Note:**

*While many Windows applications override the settings made with the printer driver, some do not, so you must verify that the printer driver settings match your requirements.*

### Accessing the printer driver from Windows applications

To access the printer driver from a Windows application, follow the steps on the next page.

**Note:**

- ❑ *The steps on the next page provide general guidelines on accessing the printer driver. How you access the printer driver may differ depending on your application. See your application manual for details.*
- ❑ *The screen shots in the following section are from the Windows NT 4.0 operating system. They may vary in appearance from what actually appears on your screen, however the instructions are the same.*

1. Select Print Setup or Print from the File menu of your application software. The Print or Print Setup dialog box appears.

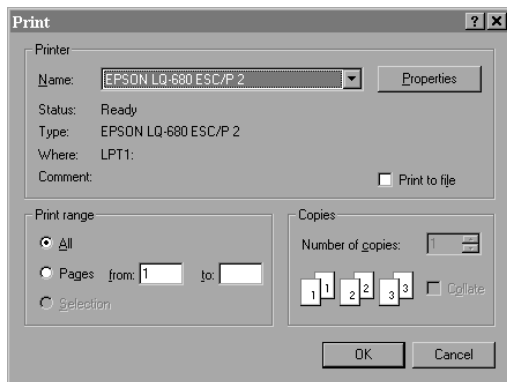

2. Make sure that your printer is selected and then click Printer, Setup, Properties, or Options. (You may need to click a combination of these buttons.) The Document Properties window appears, and you see the Page Setup and Advanced menus. These menus contain the printer driver settings.

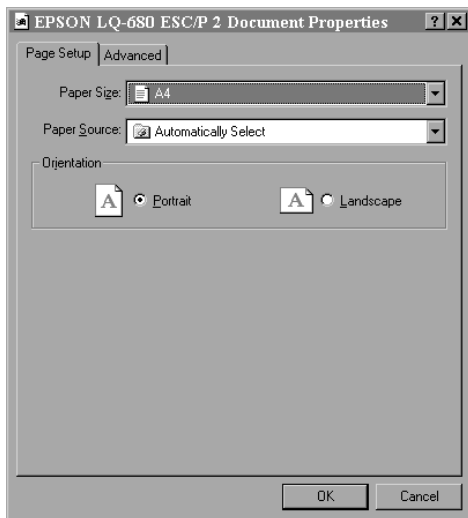

3. To view a menu, click the corresponding tab at the top of the window. See “Changing the printer driver settings” below to change the settings.

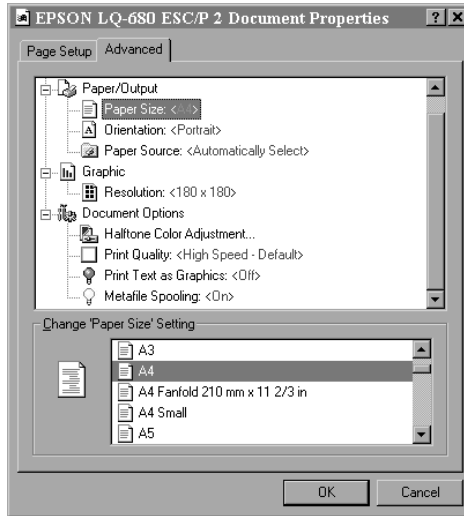

## ***Accessing the printer driver from the Start menu***

To access the printer driver from the Start menu, follow these steps:

**Note:**

*The screen shots in the following section are from the Windows NT 4.0 operating system. They may vary in appearance from what actually appears on your screen, however the instructions are the same.*

1. Click the Start button, and then point to Settings.
2. Click Printers.

3. Right-click your printer icon, and click Document Defaults. The screen displays the Default Document Properties window, which contains the Page Setup and Advanced menus. These menus display the printer driver settings.

When you click Properties, the printer software window appears, which includes Utility menu.

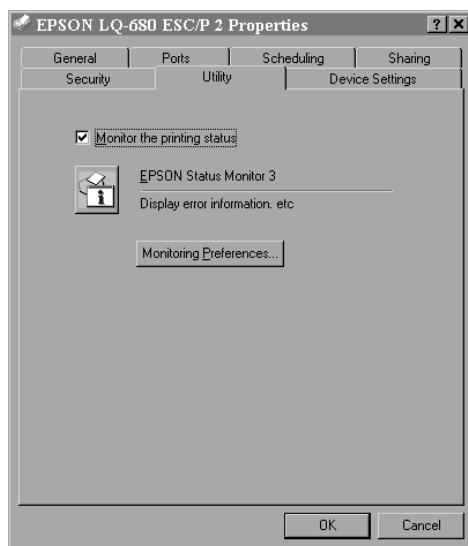

4. To view a menu, click the corresponding tab at the top of the window. See the next section to change the settings.

## ***Changing the printer driver settings***

Your printer driver has two menus from which you can change the printer driver settings, Page Setup and Advanced. You can also change settings on the Utility menu in the printer software. For an overview of the available settings, see “Printer Driver Settings Overview” on page 3-17. You can also view online help by right-clicking items in the driver and selecting What’s this?.

When you finish making your printer driver settings, click OK to apply the settings, or click CANCEL to cancel your changes.

Once you've checked your printer driver settings and changed them if necessary, you are ready to print.

---

## **Using the Printer Driver With Windows NT 3.5x**

**3**

You can access the printer driver from your Windows applications or from the Control Panel. When you access the printer driver from a Windows application, any settings you make apply only to the application you are using. See "Accessing the printer driver from Windows applications" below. When you access the printer driver from the Control Panel, the printer driver settings you make can apply to all your applications. See "Accessing the printer driver from the Control Panel" on page 3-15. To check and change printer driver settings, see "Changing the Printer driver settings" on page 3-16.

**Note:**

*While many Windows applications override the settings made with the printer driver, some do not, so you must verify that the printer driver settings match your requirements.*

### **Accessing the printer driver from Windows applications**

To access the printer driver from a Windows application, follow the steps on the next page.

**Note:**

*The steps on the next page provide general guidelines on accessing the printer driver. How you access the printer driver may differ depending on your application. See your application manual for details.*

1. Select Print Setup or Print from the File menu of your application software. The Print or Print Setup dialog box appears.

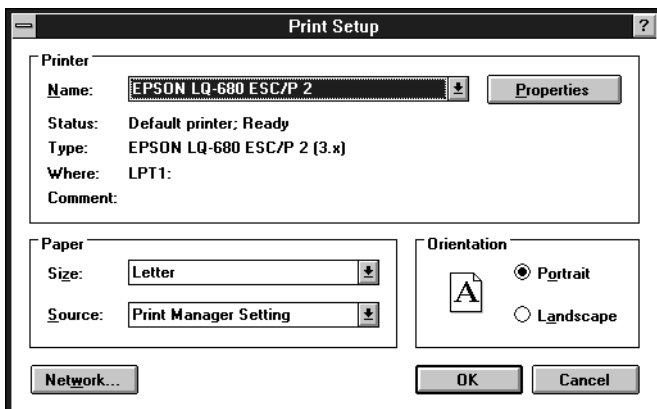

2. Make sure that your printer is selected and then click Printer, Setup, Properties, or Options. (You may need to click a combination of these buttons.) The screen displays the Document Properties dialog box, which contains the Form and Orientation printer driver settings. See “Changing the Printer driver settings” on page 3-16 to change the settings.

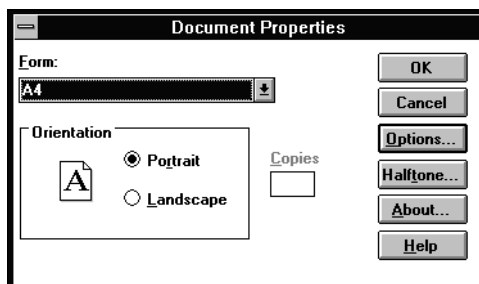



3. Click Options (or a similar button) to view the Advanced Document Properties dialog box, which includes the Graphics Resolution, Color, and Optimizations printer driver settings. See “Changing the Printer driver settings” on page 3-16 to change the settings.

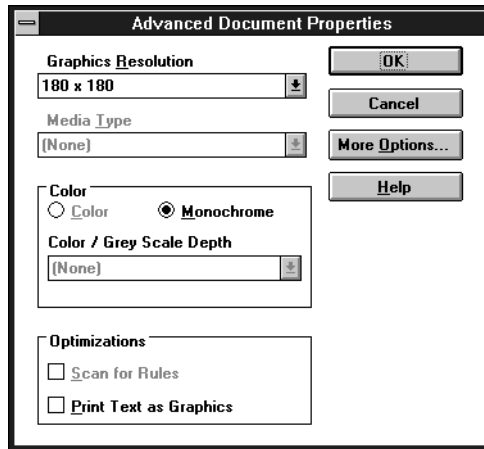

## ***Accessing the printer driver from the Control Panel***

To access the printer driver from the Control Panel, follow these steps:

1. In the Main window, double-click the Print Manager icon. The Print Manager window opens.
2. Make sure your printer is highlighted, then click Printer and select Properties. The Printer Properties dialog box appears.

3. Click the Details button, then click Job Default. You see the Document Properties dialog box, which includes the Form and Orientation printer driver settings. See “Changing the Printer driver settings” below to change the settings.
4. Click Options to open the Advanced Document Properties dialog box, which contains the Graphics Resolution, Color, and Optimizations printer driver settings. See “Changing the Printer driver settings” below to change the settings.

## ***Changing the Printer driver settings***

You can change printer driver settings in the Document Properties dialog box and the Advanced Document Properties dialog box. For an overview of the available settings, see “Printer Driver Settings Overview” on page 3-17. To open these dialog boxes, see the previous sections on accessing the printer driver.

When you finish making your printer driver settings, click OK to apply the settings, or click CANCEL to cancel your changes.

Once you’ve checked your printer driver settings and changed them if necessary, you are ready to print.

---

## Printer Driver Settings Overview

The following tables show the Windows printer driver settings. Note that not every setting is available in all versions of Windows.

The printing settings are shown below.

Settings	Explanations
Paper size	Select the size of the paper you want to use. If you don't see your paper size, use the scroll bar to scroll through the list. If your paper size is not included in the list, click Custom or User Defined Size and enter the paper size in the dialog box that appears.
Orientation	Select Portrait or Landscape.
Paper Source	Select the paper source you want to use.
Resolution/ Graphics Resolution	Select the printing resolution you want. The higher the resolution you select, the more detailed your printout will be; however, increasing the resolution slows printing. If you are using Windows 3.1, this option is only available from the Control panel.
Dithering	You can leave this option set to Fine, which is the default setting, or select another dithering pattern depending on the kind of printout you want.
Intensity/ Intensity Control	Move the slider to make your printout lighter or darker.
Print quality	Select a print quality option from the Print quality list. If you turn on Hi-speed, you will enter bi-directional printing mode and printing speed will increase. Turning Hi-speed off will return the printer to uni-directional printing mode. Printing speed will decrease, but printing precision will improve. Default printing uses the settings stored in the printer.
EPSON Status Monitor 3	You can access EPSON Status Monitor 3 when you click this button. To monitor the printer, make sure the Monitor the printing status check box is selected.

<b>Settings</b>	<b>Explanations</b>
Monitoring Preferences	Click this button to open the Monitoring Preferences dialog box where you can make settings for EPSON Status Monitor 3.
Paper/Output	Check the Paper Size, Orientation, and Paper Source settings you made on the Page Setup menu and change them if necessary. Select the setting and then choose an option from the Change Setting list box.
Halftone	Click this button to set the brightness and contrast, input the RGB gamma, or make other settings. The Halftone Color Adjustment dialog box appears. For details, click Help in this dialog box.

The monitoring settings are shown below.

<b>Settings</b>	<b>Explanations</b>
EPSON Status Monitor 3	You can access EPSON Status Monitor 3 when you click this button. To monitor the printer, make sure the Monitor the printing status check box is selected.
Monitoring Preferences	Click this button to open the Monitoring Preferences dialog box where you can make settings for EPSON Status Monitor 3. For more information, see "Setting up EPSON Status Monitor 3" on page 3-20.

---

## ***Using the EPSON Remote! Utility***

The EPSON Remote! utility allows you to easily change the printer's default settings from your computer's DOS prompt.

### ***Installing EPSON Remote!***

3

Follow the steps below to install EPSON Remote!

1. Insert the printer software CD-ROM in a disk drive.
2. At the DOS prompt, type `D:\SETUP`. (If you inserted the disk in a drive other than drive D, substitute the appropriate letter.) Then press Enter.
3. Select your printer's name in the Printer Model window and press Enter. `C:\EPUTIL` appears as the default directory.
4. Press Enter again. The EPSON Remote! utility is copied to the `C:\EPUTIL` directory.

### ***Accessing EPSON Remote!***

To access EPSON Remote!, type `C:\PRNSET` at the DOS prompt and press Enter. Then follow the on-screen instructions to use this utility. You can also access EPSON Remote! by typing `C:\PANEL` at the DOS prompt and pressing Enter. The PRNSET and PANEL access methods differ slightly. The PANEL method opens a condensed version of EPSON Remote! that only provides the most often used settings.

---

## **Using the EPSON Status Monitor 3 Utility**

The EPSON Status Monitor 3 utility that comes with your printer is available for Windows 98, 95, 2000 and NT 4.0. It allows you to monitor your printer's status, alerts you when printer errors occur, and provides troubleshooting instructions when needed.

The EPSON Status Monitor 3 utility is available only when:

- The printer is connected directly to the host computer via the parallel port [LPT1].
- Your system is configured to support bidirectional communication.

The EPSON Status Monitor 3 utility is installed when you install the printer driver as described in Chapter 1.

**Note:**

*If you install the driver using Add Printer in the Printers folder, or using the "Point and Print" method, EPSON Status Monitor 3 may not function properly. If you want to use EPSON Status Monitor 3, reinstall the driver as described in Chapter 1.*

Before using EPSON Status Monitor 3, be sure to read the README file on the driver disk. This file contains the latest information on the utility.

## **Setting up EPSON Status Monitor 3**

Follow the steps below to setup EPSON Status Monitor 3.

1. Open the Utility menu as described in "Using the Printer Driver With Windows 98 or 95" on page 3-3 or "Using the Printer Driver With Windows 2000 and NT 4.0" on page 3-9.

- Click the Monitoring Preferences button. The Monitoring Preferences dialog box appears.

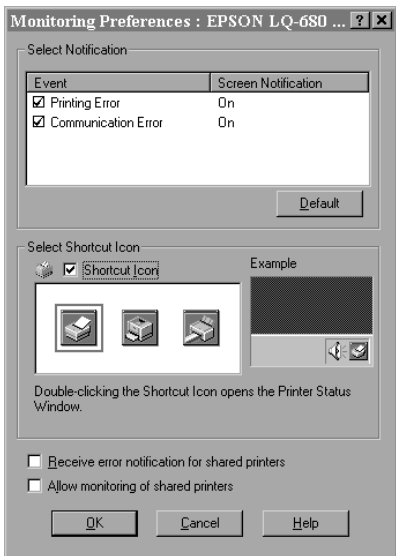

- The following settings are available:

Select Notification	Displays the error item check box ON/OFF status. Turn on this check box to display the selected error notification.
Select Shortcut icon	The selected icons are displayed in the task tray on the PC screen. The setting example is shown on the right window. By clicking the shortcut icon, you can access the Monitoring Preferences dialog easily.
Receive error notification for shared printers	Error notification for a shared printer can be received when this check box is turned on.
Allow monitoring of shared printer	When this check box is turned on, a shared printer can be monitored by other PCs.

**Note:**

Click the *Default* button to revert all items to the default settings.

## Accessing EPSON Status Monitor 3

To access EPSON Status Monitor 3:

- ❑ Double-click the printer-shaped shortcut icon on the taskbar. To add a shortcut icon to the taskbar, see Utility menu.
- ❑ Open the Utility menu, then click EPSON Status Monitor 3. To find out how to open the Utility menu, See “Using the Printer Driver With Windows 98 or 95” on page 3-3 or “Using the Printer Driver With Windows 2000 and NT 4.0” on page 3-9.

When you access EPSON Status Monitor 3 as described above, the following printer status window appears.

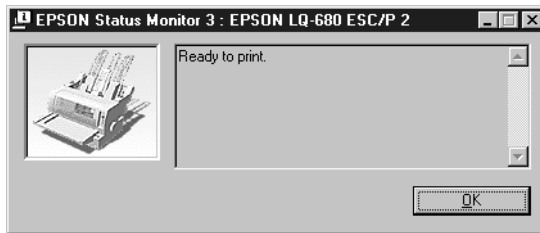

You can view printer status information in the window.



## Chapter 4

---

# ***Changing Printer Settings From the Printer's Control Panel***

Selecting a Built-In Font and Pitch . . . . .	4-2
About Your Printer's Default Settings . . . . .	4-3
Changing default settings . . . . .	4-9

---

## Selecting a Built-In Font and Pitch

Your printer comes with the twelve built-in fonts. See “Built-in fonts:” on page C-4 for information of fonts you can select. You can also change the pitch by turning the condensed mode on or off. You can select the font and pitch using the buttons on the printer’s control panel as described below.

**Note:**

*Settings you make in your application programs usually override settings you make from the printer’s control panel. For best results, use your application to select a font and pitch.*

Follow these steps to select a built-in font or pitch using the buttons on the printer’s control panel:

1. Make sure that the printer is not printing. If it is, wait until printing has finished.
2. To select a font, press the Font button until the three Font lights indicate the font you want with a pattern shown on the control panel.

**Note:**

- The Font button cannot directly select OCR-B, Orator, Orator-S, Script-C, Roman-T, or Sans Serif H. To select one of these fonts, you must first use the default-setting mode to register it as the “other” font and then select Others using the Font button.*
  - Barcode fonts can not be selected via the control panel.*
3. Press the Condensed button to turn the condensed mode on or off.

---

## About Your Printer's Default Settings

The default settings control many printer functions. While you can often set these functions through your software or printer driver, you may sometimes need to change a default setting from the printer's control panel using the default-setting mode.

The following table lists the default settings and the options you can select in the default-setting mode. The settings are explained in detail after the table. For instructions on changing the default settings, see "Changing default settings" on page 4-9.

4

Settings	Options
Page length for tractor*	Length in inches: 3, 3.5, 4, 5.5, 6, 7, 8, 8.5, 11, 70/6, 12, 14, 17
Skip over perforation	On, Off
Auto tear off	On, Off
Auto line feed	On, Off
Print direction	Bi-D, Uni-D, Auto
Software	ESC/P2, IBM 2390 Plus
0 slash	0, Ø
High speed draft	On, Off
I/F mode	Auto, Parallel, Option
Auto I/F wait time	10 seconds, 30 seconds
Parallel I/F bidirectional mode	On, Off
Packet mode	Auto, Off
Auto CR (IBM 2390 Plus)**	On, Off
A.G.M. (IBM 2390 Plus)**	On, Off

\* The options available vary depending on the country of purchase.

\*\* These settings take effect only when IBM 2390 Plus emulation is selected.

\*\*\*This option is available with the LQ-680Pro only.

<b>Settings</b>	<b>Options</b>
Character table*	Standard model: Italic, PC 437, PC 850, PC 860, PC 863, PC 865, PC 861, BRASCII, Abicomp, Roman 8, ISO Latin 1, PC 858, ISO 8859-15  All other models: Italic, PC 437, PC 850, PC 437 Greek, PC 853, PC 855, PC 852, PC 857, PC 864, PC 866, PC 869, MAZOWIA, Code MJK, ISO 8859-7, ISO Latin 1T, Bulgaria, PC 774, Estonia, ISO 8859-2, PC 866 LAT, PC 866 UKR, PC APTEC, PC 708, PC 720, PC AR864, PC 860, PC 863, PC 865, PC 861, BRASCII, Abicomp, Roman 8, ISO Latin 1, PC 858, ISO 8859-15, PC 771
International character set for Italic table	Italic U.S.A., Italic France, Italic Germany, Italic U.K., Italic Denmark1, Italic Sweden, Italic Italy, Italic Spain1
Font	OCR-B, Orator, Orator-S, Script C, Roman T (PS), Sans Serif H (PS)
Manual feed wait time	0.5 second, 1 seconds, 1.5 seconds, 2 seconds
Buzzer	On, Off
Overlapping forms***	On, Off

\* The options available vary depending on the country of purchase.

\*\* These settings take effect only when IBM 2390 Plus emulation is selected.

\*\*\*This option is available with the LQ-680Pro only.

### *Page length for tractor*

This setting allows you to set the page length for continuous paper.

### *Skip over perforation*

This feature is available only when continuous paper is selected. When you select **On**, the printer provides a one-inch (25.4 mm) margin between the last line printed on one page and the first line printed on the next page. Because the program margin settings in most applications override margin settings made from the control panel, you should use this setting only if you cannot set your top and bottom margins using your application.

### *Auto tear off*

When auto tear off is on and you are using continuous paper with the tractor, the printer automatically advances the paper perforation to the tear-off position, where you can easily tear off the printed pages. When the printer receives the next print job, it automatically moves the unused paper back to the top-of-form position and starts printing, so you can use all of the next page.

When auto tear off is off and you are using continuous paper with the tractor, you need to move the perforation to the tear-off position by pressing the control panel button. See “Using the Tear Off button” on page 2-15 for more information.

### *Auto line feed*

When auto line feed is on, the printer accompanies each carriage return (CR) code received with a line feed code, and the print position moves to the next line. If the printer adds an extra line after every carriage return, select **Off**.

### *Print direction*

You can select auto print direction (Auto), bidirectional printing (Bi-D), or unidirectional printing (Uni-D). Printing is normally bidirectional for faster printing; however, unidirectional printing allows for precise vertical printing alignment, which is useful for printing graphics.

When set to Auto, the printer analyzes the data and uses unidirectional printing only for any lines which require vertical printing alignment.

### *Software*

When you select ESC/P2, the printer operates in the EPSON ESC/P2 mode. When you select IBM 2390 Plus, the printer emulates an IBM printer.

### *0 slash*

The zero character has a slash (0) when this feature is on. It has no slash (0) when this feature is off. The slash allows you to easily distinguish between the uppercase letter "O" and a zero.

### *High speed draft*

When you choose On, the printer prints up to 413 cps (characters per second) at 10 cpi (characters per inch). When you choose Off, the printer prints up to 310 cps at 10 cpi.

### *I/F (interface) mode*

The printer comes with a built-in parallel interface and an interface slot in which you can install one optional interface. For information on using an optional interface, see “Optional interface cards” on page A-19.

If your printer is connected to only one computer, select *Parallel* or *Optional* for the interface mode, depending on the interface you use. If your printer is connected to two computers, select *Auto* (automatic) to allow the printer to automatically switch between interfaces depending on which one is receiving data.

### *Auto I/F (interface) wait time*

This setting takes effect only if an optional interface is installed and the auto interface mode is selected. This setting determines how long the printer waits when it no longer receives data from an interface before it checks whether a print job is being sent through the other interface. You can specify 10 seconds or 30 seconds for the auto interface wait time.

### *Parallel I/F bidirectional mode*

The Parallel Interface bidirectional transfer mode is used when this feature is on. If bidirectional transfer mode is unnecessary, turn this off.

### *Packet mode*

Select *Auto* to use the IEEE-1284.4 packet transfer mode. If packet transfer mode is unnecessary, or if you cannot connect, turn this off.

### *Auto CR (carriage return)*

This setting is available only in IBM 2390 Plus emulation mode. When auto carriage return is on, each line feed (LF) code or ESC J code is accompanied by a carriage return code. This moves the print position to the beginning of the next line. If the printer adds an extra line after every carriage return, select Off.

### *A.G.M. (Alternate Graphic Mode)*

When A.G.M. is on, the printer can use some advanced graphics commands like those available in ESC/P2 mode. When you select IBM 2390 Plus mode, this setting is available.

### *Character table*

You can select from among 13 to 36 standard character tables, depending on the country of purchase. See “Character tables:” on page C-5 for more information of the tables.

### *International character set for Italic table*

You can select among several international character sets for the Italic character table. Each character set contains eight characters that vary depending on the country or language, so you can customize the Italic table to suit your printing needs.

### *Font*

You can select six fonts in default-setting mode. The font selected here appears under Others in the control panel. The following fonts are indicated on the control panel and can't be selected by default settings: Draft, Roman, Sans Serif, Courier, Prestige, and Script.



### *Manual feed wait time*

This sets the amount of wait time between when paper is inserted into the paper guide and it is fed. If the paper feeds before you can adjust its position to your satisfaction, you can increase the wait time.

### *Buzzer (beeper)*

The printer beeps when an error occurs. (See “Using the Error Indicators” on page 5-2 for more information on printer errors.) If you do not want the printer to beep when an error occurs, turn this setting off.

### *Overlapping forms (LQ-680Pro only)*

This setting takes effect only when the skip-over-perforation setting is on. When overlapping-forms setting is on, the printer lifts up the print head each time it makes a one-inch margin with the skip-over-perforation feature. You need to turn on both the overlapping-forms and the skip-over-perforation settings when you use overlapping forms. This setting is available only on LQ-680Pro.

## **Changing default settings**

Follow the steps below to enter the default-setting mode and change the printer’s default settings.

### **Note:**

- ❑ *To print the language selection and default-setting mode instructions, you need five sheets of A4 or letter size single-sheet paper, or five pages of continuous paper that is at least 279 mm (11 inches) long and 210 mm (8.27 inches) wide.*
- ❑ *If you use single sheets without an optional cut-sheet feeder, you need to feed a new sheet of paper each time the printer ejects a printed sheet.*

1. Make sure paper is loaded and the printer is turned off.



**Caution:**

*Whenever you turn off the printer, wait at least five seconds before turning it back on; otherwise you may damage the printer.*

2. While holding down the FONT button, turn on the printer. The printer enters the default-setting mode and prints the language selection instructions.
3. Press the FONT button until the Font lights indicate the language you want, as described in the language selection instructions.
4. Press the Tear Off/Bin button (LQ-680) or Tear Off/Special Paper button (LQ-680Pro) to print the default-setting mode instructions (four pages) in the language you selected.

The printed instructions list the default settings you can change, describe how to change them, and show you how the control panel lights help you make settings. Follow these instructions to change the default settings using the buttons on the printer's control panel.

**Note:**

*The arrows on the instruction sheets indicate the printer's current settings.*

5. When you finish making settings, turn off the printer and exit the default-setting mode. Any settings you have made remain in effect until you change them again.

**Note:**

*To exit the default-setting mode, turn off the printer when it has finished printing.*

# Chapter 5

## **Troubleshooting**

---

Using the Error Indicators . . . . .	5-2
Problems and Solutions . . . . .	5-4
Power supply problems . . . . .	5-5
Single-sheet paper loading or feeding problems . . . . .	5-6
Continuous paper loading or feeding problems . . . . .	5-8
Printing position problems . . . . .	5-9
Printing or printout quality problems . . . . .	5-11
Clearing Paper Jams . . . . .	5-16
Aligning Vertical Lines in Your Printout . . . . .	5-17
Printing a Self Test . . . . .	5-18
Printing a Hex Dump . . . . .	5-19



## Using the Error Indicators

You can identify many common printer problems using the lights on the control panel. If your printer stops working and one or more control panel lights are on or flashing or the printer beeps, use the following table to diagnose and fix the problem. If you can't fix your problem using this table, go to the next section.

Panel light state	Beep pattern	Problem
		Solution
<input type="checkbox"/> Pause	-	<b>The printer is paused.</b>
		Press the Pause button to resume printing.
	•••	<b>Paper from another paper source is currently in the paper path. (LQ-680 only)</b>
		Move the paper release lever back to the appropriate position and press the Load/Eject button to clear the paper from the paper path. Then set the lever to the position you want to use. Press the Pause button to turn off the Pause light, if necessary.
	•••	<b>The printer cover is open.</b>
		Close the printer cover and press the Pause button.
<input type="checkbox"/> Paper Out <input type="checkbox"/> Pause	•••	<b>No paper is loaded in the selected paper source.</b>
		Load paper in the printer. Then press the Pause button to turn off the Pause light, if necessary.
	•••	<b>The paper is not loaded correctly.</b>
		Remove your paper and reload it. See Chapter 2 for instructions on loading paper. Then press the Pause button to turn off the Pause light, if necessary.
	•••	<b>Paper is jammed in the printer.</b>
		Clear the paper jam as described "Clearing Paper Jams" on page 5-16.

Panel light state	Beep pattern	Problem
		Solution
<input type="checkbox"/> Paper Out <input type="checkbox"/> Pause	•••	<b>Continuous paper is not fed back to the standby position.</b>
		Tear off the printed document at the perforation; then press the Load/Eject button. The printer feeds the paper to the standby position. Press the Pause button to turn off the Pause light.
	•••	<b>A single sheet of paper is not fully ejected.</b>
Press the Load/Eject button to eject the sheet. Then press the Pause button to turn off the Pause light, if necessary.		
•••	<b>Paper is jammed in the printer.</b>	
	Clear the paper jam as described in "Clearing Paper Jams" on page 5-16.	
<input type="checkbox"/> Paper Out <input type="checkbox"/> Pause	•••	<b>The printer was unable to switch between paper sources because of a paper jam or other paper problems. (LQ-680Pro only)</b>
		Remove any paper from the paper path and clear the paper jam as described in "Clearing Paper Jams" on page 5-16. Then retry the paper source selection.
<input type="checkbox"/> Pause	-	<b>The print head is overheated.</b>
		Wait a few minutes; the printer resumes printing automatically once the print head has cooled.
<input type="checkbox"/> All the lights on the control panel	•••••	<b>An unknown printer error has occurred.</b>
		Turn off the printer and leave it off for several minutes; then turn on the printer again. If the error recurs, contact your dealer.

- = on,  = flashing
- = short series of beeps (three beeps)
- = long series of beeps (five beeps)

**Note:**

The printer beeps once if you press a control panel button when the corresponding function is not available.

---

## ***Problems and Solutions***

Most printer problems are easy to solve. Use the information in this section to find the cause and solution to any printer problems that occur.

Determine what type of problem occurred, and see the appropriate page listed below:

Power supply problems . . . . . page 5-5

Single-sheet paper loading or  
feeding problems . . . . . page 5-6

Continuous paper loading or  
feeding problems . . . . . page 5-8

Printing position problems . . . . . page 5-9

Printing or printout quality problems . . . . . page 5-11

You can also use the self test feature to determine whether the printer or the computer is causing the problem. See “Printing a Self Test” on page 5-18 for instructions.

To pinpoint communication problems, experienced users may want to use the printer’s hex dump mode, described in “Printing a Hex Dump” on page 5-19.

To clear a paper jam, see “Clearing Paper Jams” on page 5-16.

## Power supply problems

**The control panel lights come on briefly, but then go off and stay off.**

Cause	What to do
The printer's voltage rating does not match the voltage of your electrical outlet.	Check the printer and the outlet voltage ratings. If the voltages do not match, unplug the printer immediately and contact your dealer.



### **Warning:**

*Do not reconnect the power cord to an electrical outlet that has the wrong voltage for your printer.*

**The printer does not work and the control panel lights are off even though you turned on the printer.**

Cause	What to do
The power cord is not properly plugged into the electrical outlet or your printer.	Turn off the printer, and make sure the power cord is firmly plugged into the electrical outlet and the printer, if necessary. Then turn on the printer.
The electrical outlet does not work.	Use a different outlet.

## **Single-sheet paper loading or feeding problems**

### **The printer does not load single-sheet paper or does not feed it properly.**

<b>Cause</b>	<b>What to do</b>
Tractor feeding is selected.	Select single-sheet feeding. For more information, see “Selecting a Paper Source” on page 2-2.
The paper on the paper guide is positioned too far to the left or right for the paper sensor to detect that it is there.	Move the paper a little to the left or right.
Single-sheet paper is not loaded properly.	See “Using Single Sheets” on page 2-20 for instructions on loading single-sheet paper.
The paper thickness lever is not set correctly.	See “Adjusting the Paper Thickness Lever” on page 2-6.
Your paper is creased, old, too thin, or too thick.	See the paper specifications in Appendix C and use new, clean sheets of paper.

### **The printer does not fully eject a single sheet.**

<b>Cause</b>	<b>What to do</b>
Your paper is too long.	Press the Load/Eject button to eject the sheet. Make sure the page length of your paper is within the range specified for single-sheet paper in Appendix C. Also check and adjust the paper size setting in your application or printer driver.



**The optional cut-sheet feeder does not feed your single-sheet paper properly.**

<b>Cause</b>	<b>What to do</b>
The cut-sheet feeder is not installed properly.	Reinstall it as described in “Installing the cut-sheet feeder” on page A-3.
Too many sheets are loaded in the cut-sheet feeder.	Load no more than 150 single sheets in the high-capacity cut-sheet feeder. See “Cut-Sheet Feeders” on page A-2 for more information.
You may have loaded the wrong type of paper in bin 2 of the double-bin cut-sheet feeder.	Use only the high-capacity feeder (bin 1) or the sheet guide for single-sheet multipart forms (only the type glued at the top of the forms), envelopes, and postcards.
The edge guides of the cut-sheet feeder are not positioned correctly.	Align the left edge guide with the arrow mark, then move the right edge guide to match your paper’s width.
There are only a few sheets of paper left in the bin.	Load more paper in the cut-sheet feeder.
Sheets of paper are stuck together.	Remove the paper stack, fan it, and then reload it.

## Continuous paper loading or feeding problems

### The printer does not load continuous paper or does not feed it properly.

Cause	What to do
Single-sheet feeding is selected.	Select tractor feeding. For more information, see "Selecting a Paper Source" on page 2-2.
Continuous paper is not loaded properly.	See Chapter 2 for instructions on loading continuous paper on the tractor you want to use.
The paper has come off the tractor.	Reload the paper on the tractor as described in "Loading continuous paper with the tractor" on page 2-9.
The paper thickness lever is not set correctly.	Set the paper thickness lever to match the thickness of your paper. See "Adjusting the Paper Thickness Lever" on page 2-6.
The paper supply is obstructed.	Make sure the paper supply is not obstructed by a cable or some other object. See "Positioning your continuous paper supply" on page 2-8.
The holes on the sides of the paper are misaligned.	Check that the holes on the sides of the paper are aligned with each other. Also make sure the sprocket units are locked and their covers are closed.

### The printer does not feed continuous paper back to the standby position.

Cause	What to do
You did not tear off the printed pages before pressing the Load/Eject button.	Tear off the printed pages at the perforation. Then press the Load/Eject button to feed the paper backward to the standby position.

## Printing position problems

### Printing starts too high or low on the page.

Cause	What to do
The paper size setting in your application software or printer driver does not match the size of the paper you are using.	Check the paper size setting in your application or printer driver.
The printer's page length settings for the tractor do not match the size of the continuous paper you are using.	Check the page length settings for the tractor using the printer's default-setting mode or the EPSON Remote! utility. See "About Your Printer's Default Settings" on page 4-3 or "Using the EPSON Remote! Utility" on page 3-19.
The top margin or top-of-form position setting is incorrect.	<p>Check the top margin or top-of-form position setting in your application software. See the printable area specifications in Appendix C.</p> <p>Adjust the top-of-form position in micro adjust mode. Be aware, however, that settings made in Windows applications override settings made in micro adjust mode. See "Adjusting the loading position" on page 2-28.</p>
The printer you want to use is not selected in your software.	Choose the correct printer from the Windows desktop or in your application before printing.
You moved the paper using the knob while the printer was on.	Adjust the top-of-form position using the micro adjust feature. See "Adjusting the loading position" on page 2-28.



#### **Caution:**

*Never use the knob to adjust the top-of-form position; doing so may damage the printer.*

**The printer prints on or too far away from the perforation of your continuous paper.**

Cause	What to do
The printer you want to use is not selected in your software.	Choose the correct printer from the Windows desktop or in your application before printing.
The paper size setting in your application or printer driver does not match the size of the paper you are using.	Check the paper size setting in your application or printer driver.
The printer's page length settings for the tractor do not match the size of the continuous paper you are using.	Check the page length settings for the tractor using the printer's default-setting mode or the EPSON Remote! utility. See "About Your Printer's Default Settings" on page 4-3 or "Using the EPSON Remote! Utility" on page 3-19.

## Printing or printout quality problems

### The printer does not print when the computer sends data.

Cause	What to do
The printer is paused.	Press the <b>Pause</b> button.
The interface cable is not plugged in securely.	Check that both ends of the cable between the printer and the computer are plugged in securely. If the cable is connected correctly, run a self test as described later in this chapter.
Your interface cable does not meet the printer and/or computer specifications.	Use an interface cable that meets the requirements of both the printer and computer. See “Optional interface cards” on page A-19 and your computer’s documentation.
Your software is not properly set up for your printer.	Select your printer from the Windows desktop or in your application. If necessary, install or reinstall the printer driver software as described in Chapter 1.

### The printer makes noise, but nothing prints or printing stops abruptly

Cause	What to do
The paper thickness lever is not set correctly.	Set the paper thickness lever to match the thickness of your paper. See “Adjusting the Paper Thickness Lever” on page 2-6.
The ribbon has too much slack, the ribbon has come loose, or the ribbon cartridge is not installed properly.	Remove any slack in the ribbon by turning the ribbon-tightening knob, or reinstall the ribbon cartridge as described in Chapter 1.

### **The printout is faint.**

<b>Cause</b>	<b>What to do</b>
The paper thickness lever is not set correctly.	Set the paper thickness lever to match the thickness of your paper. See “Adjusting the Paper Thickness Lever” on page 2-6.
The ribbon is worn out.	Replace the ribbon cartridge as described in Chapter 1.

### **The printout has gaps.**

<b>Cause</b>	<b>What to do</b>
The paper thickness lever is not set correctly.	Set the paper thickness lever to match the thickness of your paper. See “Adjusting the Paper Thickness Lever” on page 2-6.

### **Part of the printout is missing, or dots are missing in random positions.**

<b>Cause</b>	<b>What to do</b>
The ribbon has too much slack, the ribbon has come loose, or the ribbon cartridge is not installed properly.	Remove any slack in the ribbon by turning the ribbon-tightening knob, or reinstall the ribbon cartridge as described in Chapter 1.
The ribbon is worn out.	Replace the ribbon cartridge as described in Chapter 1.

### Lines of dots are missing in the printout.

Cause	What to do
The print head is damaged.	Stop printing and contact your dealer to have the print head replaced.



**Caution:**

*Never replace the print head yourself; you may damage the printer. Other parts of the printer must also be checked when the print head is replaced.*

### All the text is printed on the same line.

Cause	What to do
A line feed command is not sent to the printer at the end of each line of text.	Turn on the auto line feed setting using the printer's default-setting mode or the EPSON Remote! utility so that the printer automatically adds a line feed code to each carriage return. See "About Your Printer's Default Settings" on page 4-3 or "Using the EPSON Remote! Utility" on page 3-19.

### **The printout has extra blank lines between lines of text.**

<b>Cause</b>	<b>What to do</b>
Two line feed commands are being sent at the end of each line of text.	Turn off the auto line feed setting using the printer's default-setting mode or the EPSON Remote! utility. See "About Your Printer's Default Settings" on page 4-3 or "Using the EPSON Remote! Utility" on page 3-19.
The line space setting in your application software is incorrect.	Adjust the line space setting in your application software.
The skip over perforation setting is on.	Turn off the skip over perforation setting in the default-setting mode or the EPSON Remote! utility. See "About Your Printer's Default Settings" on page 4-3 or "Using the EPSON Remote! Utility" on page 3-19.

### **The printer prints strange symbols, incorrect fonts, or other inappropriate characters.**

<b>Cause</b>	<b>What to do</b>
Your printer and computer are not communicating correctly.	Make sure that you are using the correct interface cable and that the communications protocol is correct. See your computer documentation. If you installed an optional serial interface card, also see "Optional interface cards" on page A-19.
The wrong character table is selected in your software.	Select the correct character table using your software, the default-setting mode, or the EPSON Remote! utility. The character table setting in your software overrides settings made in the default-setting mode or the EPSON Remote! utility.



The printer you want to use is not selected in your software.	Choose the correct printer from the Windows desktop or in your application before printing.
Your application software is not configured correctly for your printer.	Make sure that your application software is set up correctly for your printer. See your application documentation. If necessary, install or reinstall the printer driver software as described in Chapter 1.
Software settings override settings you make using the default-setting mode, EPSON Remote!, or the control panel buttons.	Use your application software to select the font.

**Vertical printed lines are not aligned.**

Cause	What to do
Bidirectional printing, which is the printer's standard printing mode, is out of alignment.	Use the printer's bidirectional adjustment mode to correct this problem. See "Aligning Vertical Lines in Your Printout," later in this chapter.

---

## Clearing Paper Jams

To clear a paper jam, follow these steps:

1. Turn off the printer.
2. Open the printer cover.
3. If continuous paper is loaded in the printer, remove it or tear off the supply at the back of the printer.
4. Turn the knob on the right side of the printer toward you to eject the paper in the printer. Remove any remaining pieces of paper.



**Caution:**

*Only use the knob to clear paper jams when the printer is off. Otherwise, you may damage the printer or lose the top-of-form or tear-off position.*

5. Close the printer cover.



**Caution:**

*The printer pauses and cannot print when the printer cover is open.*

6. Turn on the printer. Make sure the Paper Out and Pause lights are off.

---

## Aligning Vertical Lines in Your Printout

If you notice that the vertical lines in your printout are not properly aligned, you can use the printer's bidirectional adjustment mode to correct this problem.

**Note:**

- ❑ *To complete the steps below, you need four sheets of A4 or letter size single-sheet paper or four pages of continuous paper that are at least 279 mm (11 inches) long and 241 mm (9.5 inches) wide.*
- ❑ *If you use single sheets without an optional cut-sheet feeder, you need to load a new sheet of paper each time the printer ejects a printed sheet onto the paper guide.*

Follow these steps to perform the bidirectional adjustment:

1. Make sure paper is loaded and the printer is turned off.



**Caution:**

*Whenever you turn off the printer, wait at least five seconds before turning it back on; otherwise you may damage the printer.*

2. While holding down the PAUSE button, turn on the printer. The printer enters the bidirectional adjustment mode and then prints instructions and the first set of alignment patterns.
3. As described in the instructions, compare the alignment patterns and select the pattern with the best alignment.
4. Follow the instructions to print the remaining sets of alignment patterns and select the pattern with the best alignment in each set.
5. After you select the best pattern in the final set of alignment patterns, turn off the printer and exit the bidirectional adjustment mode. Your selections are saved automatically.

---

## Printing a Self Test

Running the printer's self test helps you determine whether the printer or the computer is causing the problem:

- ❑ If the self test results are satisfactory, the printer is working properly and the problem probably results from your printer driver settings, application settings, computer, or interface cable. (Be sure to use a shielded interface cable.)
- ❑ If the self test does not print properly, there is a problem with the printer. See "Problems and Solutions" for possible causes and solutions to the problem.

You can print a self test using either single sheets or continuous paper.

**Note:**

*Self test prints characters on the full width of the printable area. Use paper that is at least 297 mm (11.6 inches) wide, such as an A3-size sheet.*

To perform a self test, follow these steps:

1. Make sure paper is loaded and the printer is turned off.



**Caution:**

*Whenever you turn off the printer, wait at least five seconds before turning it back on; otherwise you may damage the printer.*

2. To run the test using the Draft font, hold down the LF/FF button while you turn on the printer. To run the test using the printer's letter-quality fonts, hold down the Load/Eject button while you turn on the printer.

After a few seconds, the printer loads the paper automatically and begins printing a self test. A series of characters is printed.

3. To end the self test, press the P<sub>o</sub>use button to stop printing. Then eject or tear off the printed page(s) and turn off the printer.

---

## ***Printing a Hex Dump***

If you are an experienced user or a programmer, you can print a hexadecimal dump to isolate communication problems between the printer and your software program. In hex dump mode, the printer prints all data received from the computer as hexadecimal values.

You can print a hex dump using either single sheets or continuous paper.

***Note:***

*Use continuous paper that is at least 241 mm (9.5 inches) wide or A4 or letter size single-sheet paper.*

To print a hex dump, follow the steps below.

1. Make sure paper is loaded and the printer is turned off.



**Caution:**

*Whenever you turn off the printer, wait at least five seconds before turning it back on; otherwise you may damage the printer.*

2. To enter hex dump mode, hold down both the LF/FF and Load/Eject buttons while you turn on the printer.
3. Open a software program and send a print job to the printer. Your printer prints all the codes it receives in hexadecimal format.

If codes are printable, they appear in the right column as ASCII characters. Nonprintable codes, such as control codes, are represented by dots.

4. To turn off hex dump mode, press the P`OUSE` button to stop printing. Then eject or tear off the printed page(s) and turn off the printer.

---

## **Enhancing Your Printer With Options**

Cut-Sheet Feeders . . . . .	A-2
Installing the cut-sheet feeder. . . . .	A-3
Loading paper from the cut-sheet feeder . . . . .	A-6
Switching between the tractor and the cut-sheet feeder. . .	A-13
Loading paper manually from the paper guide . . . . .	A-14
Roll Paper Holder . . . . .	A-15
Installing the roll paper holder. . . . .	A-15
Loading a roll of paper . . . . .	A-17
Removing roll paper . . . . .	A-18
Optional interface cards . . . . .	A-19
Installing an interface card . . . . .	A-20



---

## Cut-Sheet Feeders

Two cut-sheet feeders are available for use with your printer:

High capacity (bin 1)	Second bin (bin 2)
C80687*	C80679*

The asterisk (\*) is a substitute for the last digit, which varies by country. Contact your local EPSON dealer for the part number in your country.

You can install the high-capacity cut-sheet feeder by itself, or you can assemble and install a double-bin cut-sheet feeder by combining the high-capacity and second-bin feeders. When the double-bin cut-sheet feeder is installed, the high-capacity cut-sheet feeder is used as bin 1 and the second-bin feeder is used as bin 2.

**Note:**

- The second-bin feeder can be used only in combination with the high-capacity feeder.*
- The second-bin feeder can not be detached from the high-capacity feeder after you have combined them.*

Before you install a cut-sheet feeder, read the manual that comes with it. The cut-sheet feeder manual provides instructions on how to combine the two cut-sheet feeders to create the double-bin cut-sheet feeder.

You can load up to 150 single sheets of paper, 40 single-sheet multipart forms, 25 envelopes, or 50 postcards in the high-capacity cut-sheet feeder (bin 1 of the double-bin feeder). You can load an additional 50 single sheets in the second-bin cut-sheet feeder (bin 2 of the double-bin feeder). With the double-bin cut-sheet feeder, you can load two different types or sizes of paper at one time.

**Note:**

*For detailed paper specifications, see Appendix C.*



## ***Installing the cut-sheet feeder***

The cut-sheet feeder comes with a paper guide for stacking printed sheets. To install the cut-sheet feeder, you need to attach both the cut-sheet feeder and the paper guide. Follow the steps below.

**Note:**

- ❑ *The second-bin feeder can be used only in combination with the high-capacity feeder.*
  - ❑ *Install both the high capacity cut-sheet feeder and the double-bin cut-sheet feeder the same way, as described below. Before you install the double-bin cut-sheet feeder, assemble it as described in the cut-sheet feeder manual.*
1. Make sure the printer is turned off.
  2. Close the sprocket covers if they are open, and lock the sprocket units by pushing down the lock levers if necessary.

**Note:**

*You do not need to remove your continuous paper from the tractor to use the cut-sheet feeder. For information on switching between the cut-sheet feeder and continuous paper, see Chapter 2, "Switching Between Continuous Paper and Single Sheets."*

**A**

3. Hold the cut-sheet feeder by placing your hands on both sides of it. While holding down the buttons on both sides, fit the notches on each side of the feeder over the mounting posts on the printer. Lower the cut-sheet feeder until it rests on the printer.

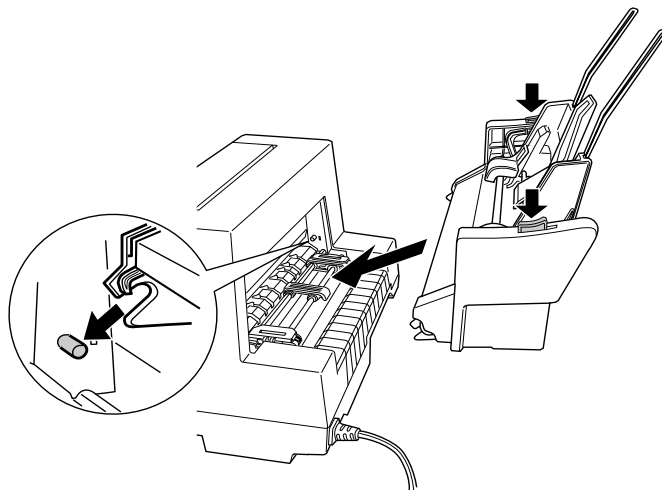

4. Remove the paper guide from the front of the printer. Then slide the paper guide for the cut-sheet feeder all the way onto the mounting pegs.
5. Slide the edge guide all the way to the left.

6. Fully extend the paper guide extension. (If you do not plan to stack the printed sheets, you do not need to perform this step.)

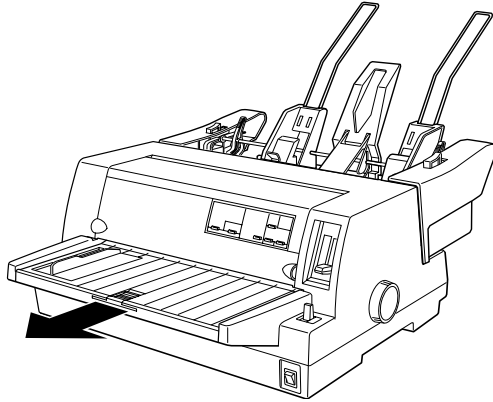

7. If you are printing on long paper, pull out the extension flap located in the center of the paper guide.

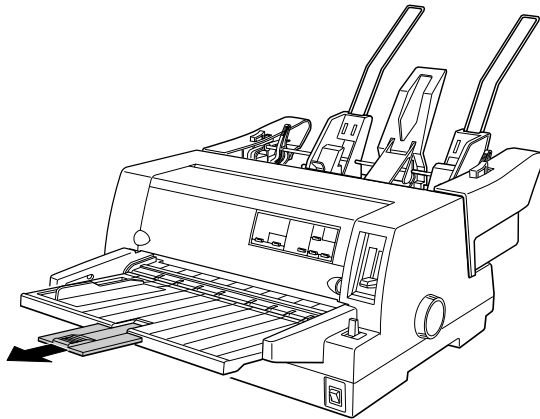

You are now ready to load paper with your cut-sheet feeder as described in the next section. To remove the cut-sheet feeder, turn off the printer and reverse the steps above.

**Note:**

*Even if you are not using the cut-sheet feeder, you can use its paper guide instead of the standard paper guide. See “Loading paper manually from the paper guide” on page A-14 for more information.*

## **Loading paper from the cut-sheet feeder**

This section describes how to load paper in the high-capacity and second-bin cut-sheet feeders.

**Note:**

- ❑ *Load single-sheet multipart forms, envelopes, and postcards only in the high-capacity cut-sheet feeder (bin 1 of the double-bin cut-sheet feeder).*
- ❑ *For single-sheet multipart forms, use only the type that are glued at the top of the forms.*
- ❑ *To avoid paper jams, do not allow the printer to stack more than 40 printed sheets on the paper guide at one time.*



**Caution:**

*Do not use labels in the cut-sheet feeder.*

## Loading paper from the high-capacity cut-sheet feeder

Load paper in the high-capacity cut-sheet feeder (bin 1 of the double-bin feeder) as follows:

1. Pull both paper set levers forward until the paper guides retract to allow paper loading.

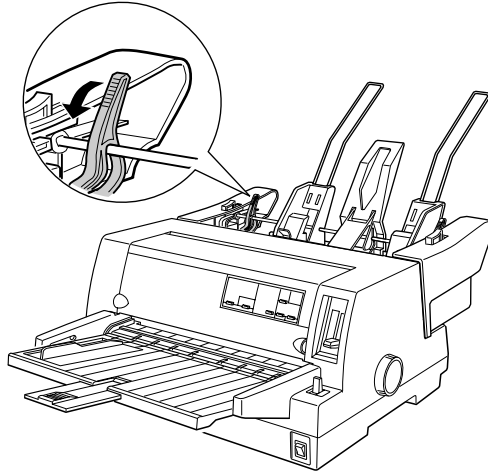

2. Release the paper guide lock levers by pulling them forward.

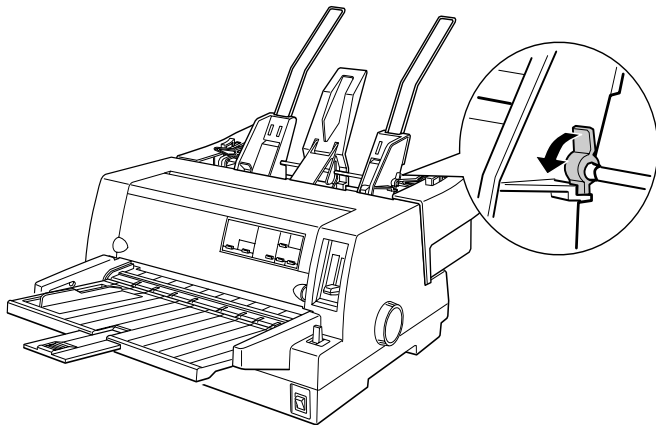

A

- Slide the right paper guide so that its edge is even with the guide mark on the cut-sheet feeder and push back the lever to lock the paper guide in place. Next, slide the left paper guide to roughly match the width of your paper.

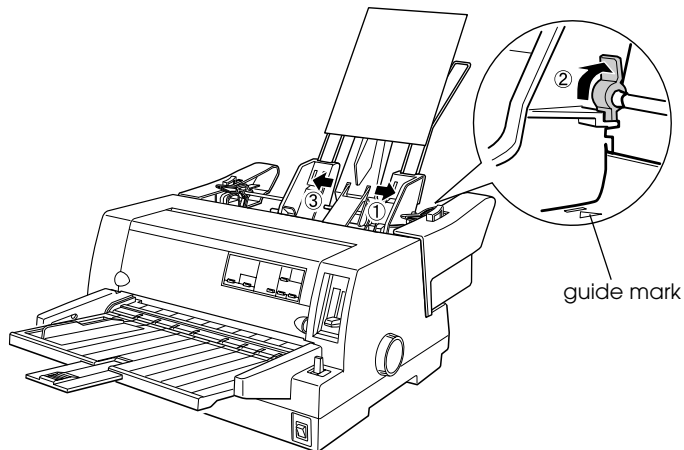

- Slide the center support midway between the paper guides.

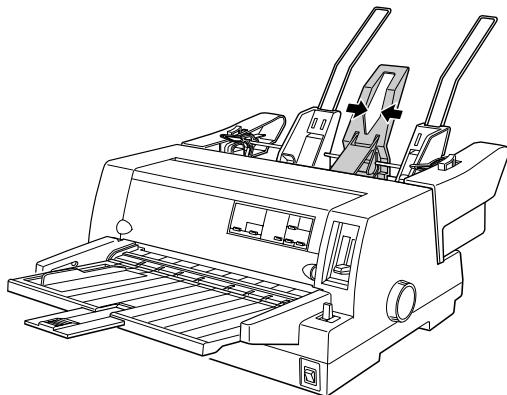

5. Fan a stack of paper (up to 150 sheets); then tap the sides and bottom of the stack on a flat surface to even it up.
6. Insert the paper along the right paper guide and adjust the position of the left paper guide so that it matches your paper's width. Make sure the position of the guide allows the paper to move up and down freely. Then lock the left guide in place.

**Note:**

*Load paper with the printable side up. If you are using pre-printed forms, load the forms top-down.*

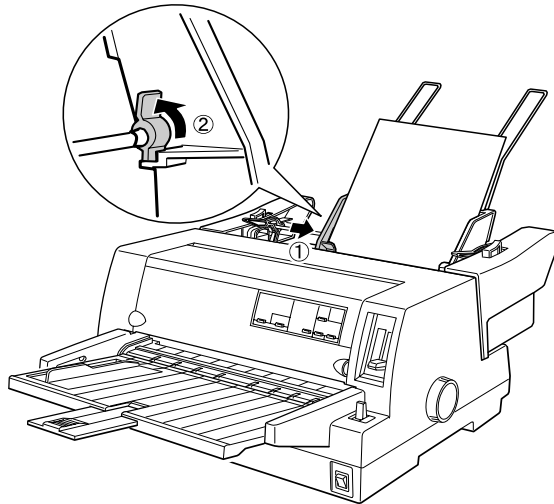

A

7. Push back the paper set levers to clamp the paper against the guide rollers.

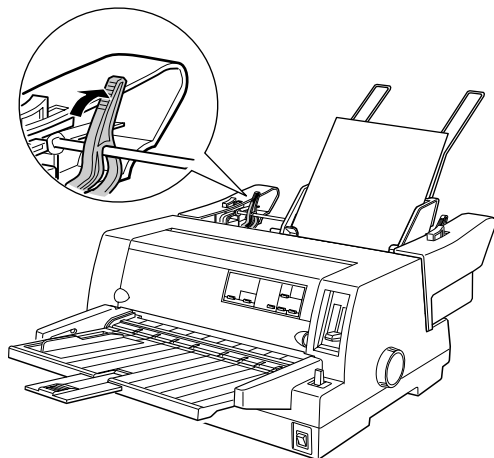

8. Before printing, make sure single sheet feeding is selected. Also adjust the thickness setting to the paper loaded in the cut-sheet feeder. See “Adjusting the Paper Thickness Lever” on page 2-6 for details.
9. In your printer driver software, select your paper size from the Paper Size list, and select Sheet Feeder Bin-1 from the Paper Source list. (If you are printing from a DOS application, select the bin number using the Tear Off/Bin button (LQ-680) or the Paper Source button (LQ-680Pro) on the control panel. If you use envelopes or postcards, select Card or Envelope on the control panel as described in “Using Envelopes” and “Using Postcards” in Chapter 2.)

The cut-sheet feeder loads paper when you send data to the printer. You can also load paper by pressing the Load/Eject button.



## Loading paper from the second-bin cut-sheet feeder

Follow the steps below to load paper in the second bin of the double-bin cut-sheet feeder.

**Note:**

*You cannot use the second-bin cut-sheet feeder without the high-capacity cut-sheet feeder, although the illustrations here show only the second-bin feeder.*

1. Pull both paper set levers forward, and slide the right paper guide to the guide mark and the left paper guide all the way to the left.

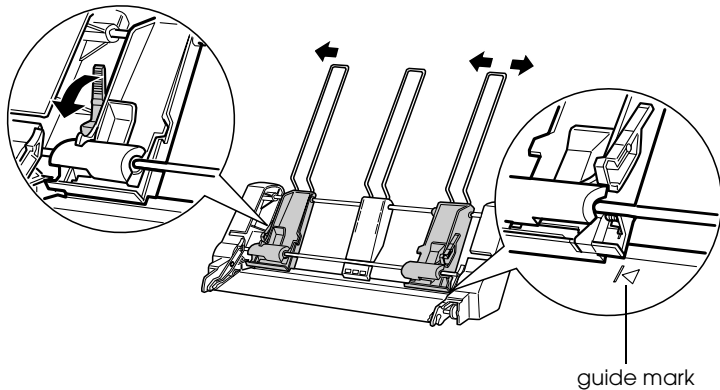

A

2. Load a fanned stack of paper (up to 50 sheets), aligning the right edge of the paper with the right paper guide. Be sure to load the paper with the printable side up. Adjust the left paper guide and center support to fit the paper, and then push back the paper set levers to lock the paper in place.

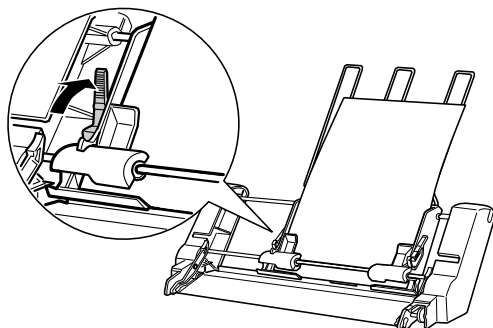

3. Before printing, make sure single sheet feeding is selected. Also adjust the thickness setting to the paper loaded in the cut-sheet feeder. See “Selecting a Paper Source” on page 2-2 and “Adjusting the Paper Thickness Lever” on page 2-6 for details.
4. In your printer driver software, select your paper size from the Paper Size list, and select Sheet Feeder Bin-2 from the Paper Source list. (If you are printing from a DOS application, select the bin number using the Tear Off/Bin button (LQ-680) or the Paper Source button (LQ-680Pro) on the control panel.)

The cut-sheet feeder loads paper when you send data to the printer. You can also load paper by pressing the Load/Eject button.

## ***Switching between the tractor and the cut-sheet feeder***

You can easily switch between continuous paper loaded from the tractor and single sheets loaded from the cut-sheet feeder without removing your continuous paper.

### ***Switching to continuous paper***

Follow the steps below to switch to continuous paper loaded from the tractor.

1. If any single sheets are in the paper path, press the Load/Eject button to eject them.
2. Select the continuous-paper feeding, as described in Chapter 2, “Selecting a Paper Source.”
3. Make sure the paper guide’s extension flap is returned to its original position, and push the paper guide extension all the way in.

A

### ***Switching to single sheets***

To switch back to single sheets loaded from the cut-sheet feeder, follow these steps:

1. If any continuous paper remains in the printer, press the Tear Off/Bin button (LQ-680) or the Tear Off/Special Paper button (LQ-680Pro) to advance the paper to the tear-off position.
2. Tear off the printed pages.
3. Press the Load/Eject button. The printer feeds the paper backward to the standby position. The paper is still attached to the tractor but is no longer in the paper path.

4. Select single-sheet feeding, as described in Chapter 2, “Selecting a Paper Source.”
5. Pull out the paper guide extension, and pull out the extension flap if you are printing on long paper.

## ***Loading paper manually from the paper guide***

The cut-sheet feeder’s single-sheet loading feature allows you to switch to a different type or size of paper without replacing the paper already in the cut-sheet feeder or removing the feeder. Follow these steps:

1. Make sure that the single-sheet feeding is selected, as described in Chapter 2, “Selecting a Paper Source.”
2. Adjust the thickness setting to your paper as described in Chapter 2, “Adjusting the Paper Thickness Lever.”
3. Return the paper guide’s extension flap to its original position, if necessary, and push the paper guide extension all the way in.

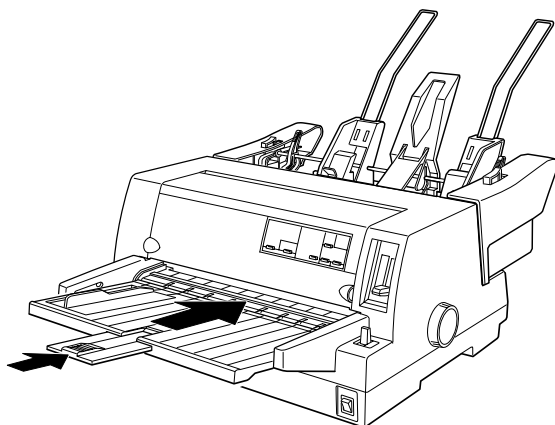

4. Slide the edge guide until it is aligned with the guide mark on the paper guide.
5. Insert a sheet of paper along the edge guide until it meets resistance. Be sure to load your paper printable side up. After a few seconds, the printer automatically advances the paper to the loading position. The printer is ready to accept data from your computer and print.

After printing a sheet, the printer ejects the printed sheet onto the paper guide and the Paper Out and Pause lights come on. If you are printing a multiple-page document, remove the printed sheet and insert a new sheet into the paper guide. The printer automatically advances the paper and resumes printing.

---

## ***Roll Paper Holder***

The optional roll paper holder (#8310) allows you to use your printer with 8.5-inch roll paper like that used in telex machines.

***Note:***

*This option is not available in some countries.*

## ***Installing the roll paper holder***

To install the roll paper holder, follow the steps below.

1. Turn off the printer.

2. Facing the back of the printer, slide both sprocket units all the way to the right, and slide the edge guide all the way to the right.

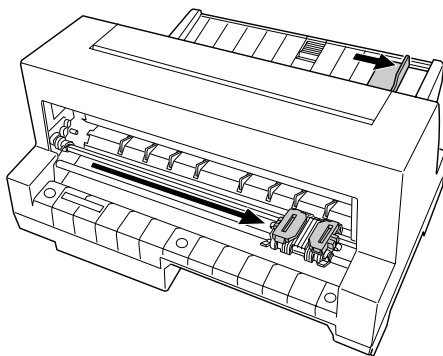

3. Position the roll paper holder beneath the printer as shown below. Fit the two holes in the roll paper holder base under the two positioning pegs on the bottom of the printer. Gently lower the printer so the positioning pegs slide into the holes.

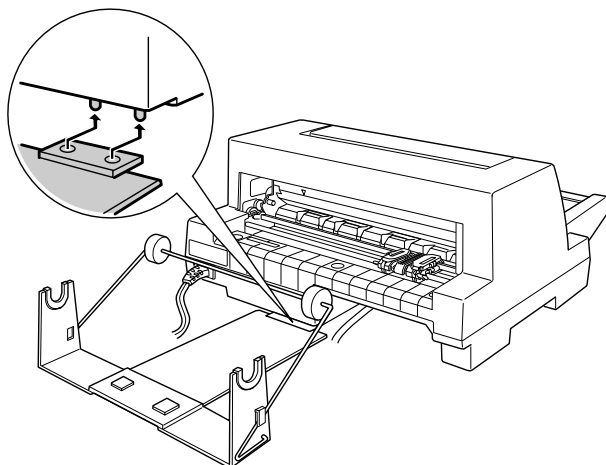

**Caution:**

*Take care not to drop the roll paper holder when lifting the printer. Only the printer's weight holds it in place.*

## Loading a roll of paper

To load a roll of paper on the roll paper holder, follow these steps:

1. Cut the leading edge of the roll paper straight across. Slide the roll paper holder shaft through the center of the paper roll.

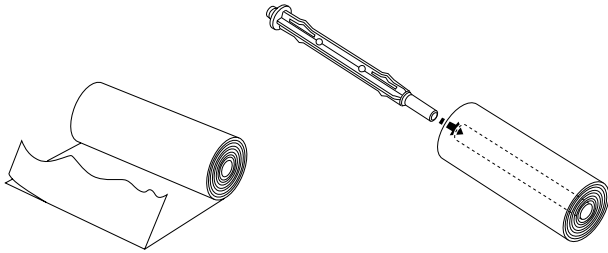

2. Set the shaft and paper roll onto the roll paper holder. Load the roll so the paper feeds from the top of the roll and the edge of the roll paper passes under the tension lever.

**A**

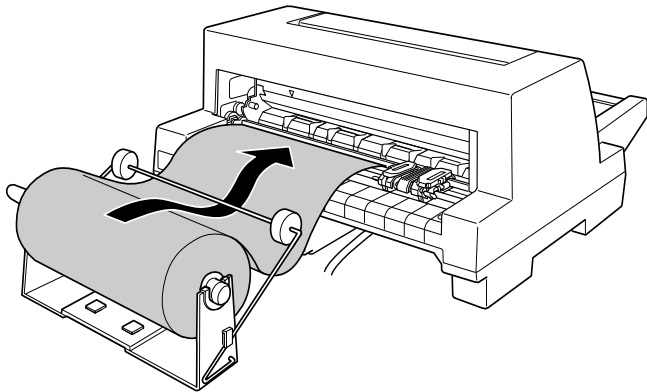

3. Turn on the printer and make sure that the single-sheet feeding is selected as described in Chapter 2, “Selecting a Paper Source.”
4. Bring the leading edge of the paper up over the paper path guide and insert it into the printer until you feel resistance. The printer loads the roll paper automatically.

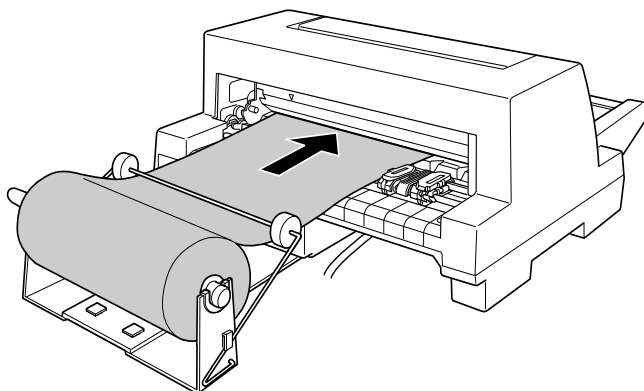

## ***Removing roll paper***

Roll paper cannot be fed backward. To remove roll paper, cut the paper behind where it feeds into the printer. Press the Load/Eject button to eject the remaining paper.



---

## Optional interface cards

You can install an optional interface card to supplement your printer's built-in parallel interface and provide added network compatibility. The EPSON interface cards in the table below are compatible with your printer. (Not all the interfaces in the table are available worldwide.)

Model number	Card type
C82305* / C82306*	Serial interface card
C82307* / C82308*	32KB serial interface card
C82312*	LocalTalk interface card
C82313*	32KB IEEE-488 interface card
C82314*	Coax interface card
C82315*	Twinaxial interface card
C82345*	IEEE-1284 (Type B bidirectional) parallel interface card
C82362*/C82363*/ C82364*	Ethernet interface card
C82384*	EpsonNet 10/100 Base Tx Int. Print Server

The asterisk (\*) is a substitute for the last digit, which varies by country.

When you use Ethernet interface card C82363\*, you need to attach the optional interface adapter (C82525\*) to the interface card.



**Caution:**

*If you install the C82305\*/C82306\* optional serial interface card, be sure to set the transfer speed to one of the following:*

*300, 600, 1200, 2400, 4800, 9600, 19200 bps*

If you are unsure whether you need an optional interface or would like to know more about interfaces, contact your dealer.

## Installing an interface card

Follow the steps below to install an optional interface card.

1. Make sure the printer is turned off. Unplug the printer's power cord and disconnect the interface cable.
2. Remove the screws securing the shield plate to the back of the printer and remove the plate.

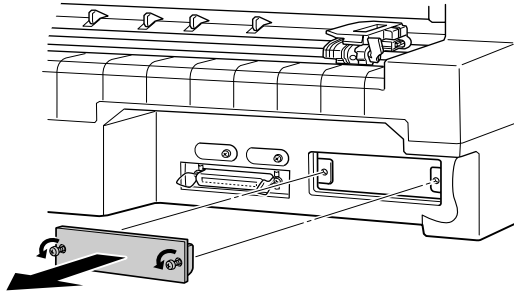

3. Slide the interface card along the slots on both sides of the interface compartment. Firmly push in the card to make sure the connector at the back of the card is fully inserted into the printer's internal socket. Then reinsert the screws and tighten them.

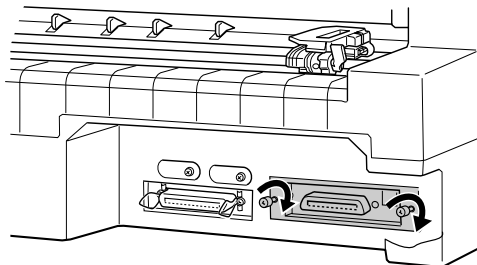

**Note:**

- ❑ *Insert the card bottom face up. The bottom face is the face usually covered with metal plate.*
- ❑ *Store the detached shield plate in a safe place; you will need to reattach it if you remove the interface card.*

To remove the interface card, reverse the steps above.



*Appendix B*

---

***Cleaning and Transporting the Printer***

Cleaning the Printer .....B-2

Transporting the Printer.....B-3

**B**

---

## ***Cleaning the Printer***

To keep your printer operating at its best, you should clean it thoroughly several times a year. To clean your printer, follow these steps:

1. Remove any paper loaded in the printer. Make sure the printer is turned off.
2. Remove the paper guide. If an optional cut-sheet feeder is installed, remove it.
3. Use a soft brush to carefully brush away all dust and dirt from the outer case and paper guide.
4. If the outer case or paper guide is still dirty or dusty, clean them with a soft, clean cloth dampened with mild detergent dissolved in water. Keep the printer cover closed to prevent water from getting inside the printer.



***Caution:***

- Never use alcohols or thinners to clean the printer; these chemicals can damage the printer components as well as the case.*
- Be careful not to get water on the printer mechanism or electronic components.*
- Do not use a hard or abrasive brush.*
- Do not spray the inside of the printer with lubricants; unsuitable lubricants can damage the printer mechanism. Contact your EPSON dealer if you think lubrication is needed.*

---

## Transporting the Printer

If you need to transport your printer some distance, carefully repack it using the original box and packing materials, as described below.



**Warning:**

*You need to move the print head by hand to remove the ribbon cartridge. If you have just used the printer, the print head may be hot; let it cool for a few minutes before touching it.*

1. Remove any paper loaded in the printer.
2. Make sure the printer is turned off.
3. Unplug the power cord from the electrical outlet; then disconnect the interface cable from the printer.
4. Remove the paper guide. If any options are installed, remove them and pack them in their original boxes.
5. Open the printer cover.
6. Make sure that the print head is not hot. Then remove the ribbon cartridge as described in Chapter 1, "Installing or Replacing the Ribbon Cartridge."
7. Repack the printer, ribbon cartridge, paper guide, and power cord in the original packing materials and place them in the printer's original box.





---

**Specifications**

Printer Specifications .....C-2

- Mechanical.....C-2
- Electronic.....C-4
- Electrical.....C-6
- Environmental .....C-6
- Paper.....C-6
- Printable area .....C-11
- Safety approvals.....C-14
- CE marking.....C-14

Command Lists .....C-15

- EPSON ESC/P2 control codes .....C-15
- IBM 2390 Plus emulation control codes .....C-16



---

# Printer Specifications

## Mechanical

Printing method:	24-pin impact dot matrix	
Printing speed:	High-speed draft	413 cps at 10 cpi
	Draft	310 cps at 10 cpi 372 cps at 12 cpi 465 cps at 15 cpi
	Draft condensed	264 cps at 17 cpi 310 cps at 20 cpi
	LQ	103 cps at 10 cpi 124 cps at 12 cpi 155 cps at 15 cpi
	LQ condensed	175 cps at 17 cpi 206 cps at 20 cpi
Printing direction:	Bidirectional logic seeking for text and graphics printing. Unidirectional text or graphics printing can be selected using software commands.	
Line spacing:	1/6-inch or programmable in 1/360-inch increments	
Printable columns:	106 columns (at 10 cpi)	
Resolution:	360 × 180 dpi maximum	
Paper feed methods:	Friction (front paper entry) Push tractor (rear paper entry) Cut-sheet feeders (optional) Roll paper holder (optional)	
Paper feed speed:	Continuous	127 mm/second (5 inches/second)
	Intermittent	64 msec/line at 1/6-inch line spacing

Paper capacity: High-capacity cut-sheet feeder  
up to 150 sheets of 82 g/m<sup>2</sup> (22 lb) paper  
up to 25 plain or bond envelopes  
up to 30 airmail envelopes  
up to 50 postcards

**Note:**

*The total thickness of the paper stack can be up to 15 mm (0.59 inch).*

Single-bin cut-sheet feeder  
up to 50 sheets of 82 g/m<sup>2</sup> (22 lb) paper

**Note:**

*The total thickness of the paper stack can be up to 5 mm (0.20 inch).*

Reliability: Total print volume 20 million lines  
(except print head)  
MTBF 10,000 POH  
(25% duty)  
Print head life 400 million strokes  
per wire

Acoustic noise: Approx. 55 dB (A) (ISO 7779 pattern)

Dimensions and weight: Height 230 mm (9 inches)  
Width 497 mm (19.6 inches)  
Depth 387 mm (15.2 inches)  
Weight LQ-680  
approx. 9.0 kg (19.8 lb)  
LQ-680Pro  
approx. 9.4 kg (20.7 lb)

Ribbon: Black ribbon cartridge (S015016)  
Ribbon life 2 million characters  
(LQ, 10 cpi, 48 dots/  
character)



# Electronic

Interfaces: One standard bidirectional 8-bit parallel interface with IEEE 1284 nibble mode support and one optional interface slot

Buffer: 64KB

Built-in fonts:

*Bitmap fonts*

EPSON Draft 10, 12, 15 cpi

EPSON Roman 10, 12, 15 cpi,  
proportional

EPSON Sans Serif 10, 12, 15 cpi,  
proportional

EPSON Courier 10, 12, 15 cpi

EPSON Prestige 10, 12 cpi

EPSON Script 10 cpi

EPSON OCR-B 10 cpi

EPSON Orator 10 cpi

EPSON Orator-S 10 cpi

EPSON Script C proportional

*Scalable fonts*

EPSON Roman 10.5, 8-32 pt  
(every 2 pt)

EPSON Sans Serif 10.5, 8-32 pt  
(every 2 pt)

EPSON Roman T 10.5, 8-32 pt  
(every 2 pt)

EPSON Sans Serif H 10.5, 8-32 pt  
(every 2 pt)

*Barcode fonts*

EAN-13, EAN-8, Interleaved 2 of 5, UPC-A, UPC-E, Code 39, Code 128, POSTNET

Character tables: One Italic and 12 graphical character tables:  
Italic table,  
PC 437 (US, Standard Europe),  
PC 850 (Multilingual),  
PC 860 (Portuguese),  
PC 861 (Icelandic), PC 865 (Nordic),  
PC 863 (French-Canadian),  
BRASCII, Abicomp, ISO Latin 1,  
Roman 8, PC 858, ISO 8859-15

Following 23 graphical character tables are also available in some countries:

PC 437 Greek,  
PC 852 (Eastern Europe),  
PC 853 (Turkish), PC 855 (Cyrillic),  
PC 857 (Turkish), PC 866 (Russian),  
PC 864 (Arabic), PC 869 (Greek),  
MAZOWIA (Poland),  
Code MJK (CSFR),  
ISO 8859-7 (Latin/Greek),  
ISO Latin 1T (Turkish),  
Bulgaria (Bulgarian),  
PC 774 (LST 1283: 1993),  
Estonia (Estonian),  
PC 771 (Lithuanian), ISO 8859-2,  
PC 866 LAT. (Latvian),  
PC 866 UKR (Ukrainian),  
PC APTEC (Arabic), PC 708 (Arabic),  
PC 720 (Arabic), PC AR 864 (Arabic)

Character sets: 14 international character sets and one legal character set:  
USA, France, Germany, UK, Denmark I,  
Sweden, Italy, Spain I  
Japan, Norway, Denmark II, Spain II,  
Latin America, Korea, Legal  
Latter 7 sets can be selected only with the ESC R command.



## Electrical

	120 V Model	220 to 240 V Model
Input voltage range	99 to 132 V	198 to 264 V
Rated frequency range	50 to 60 Hz	
Input frequency range	49.5 to 60.5 Hz	
Rated current	1.0 A (maximum 2.5 A depending on the character type)	0.5 A (maximum 1.4 A depending on the character type)
Power consumption	Approx. 42 W (ISO/IEC 10561 letter pattern)	

**Note:**

*Check the label on the back of the printer for the voltage of your printer.*

## Environmental

	Temperature	Humidity (without condensation)
Operation	5 to 35 °C (41 to 95 °F)	10 to 80% RH
Storage	-30 to 60 °C (-22 to 140 °F)	0 to 85% RH

## Paper

**Note:**

- Use recycled paper, postcards, envelopes, and labels only under normal temperature and humidity conditions, as follows:*

*Temperature*            15 to 25 °C (59 to 77 °F)

*Humidity*                30 to 60% RH

- Do not load paper that has been folded or is damaged, wrinkled, or curled.*

## Ordinary single sheets: front and cut-sheet feeder entry

Width	Front:
	90 to 304.8 mm (3.5 to 12 inches)
	Cut-sheet feeders:
	100 to 297 mm (3.9 to 11.6 inches)
Length	Front:
	70 to 420 mm (2.8 to 16.5 inches)
	High-capacity cut-sheet feeder:
	70 to 420 mm (2.8 to 16.5 inches)
	Second-bin cut-sheet feeder:
	210 to 420 mm (8.2 to 16.5 inches)
Thickness	Front:
	0.065 to 0.19 mm (0.0025 to 0.0074 inch)
	Cut-sheet feeders:
	0.065 to 0.12 mm (0.0025 to 0.0047 inch)
Weight	Front:
	52 to 157 g/m <sup>2</sup> (14 to 42 lb)
	Cut-sheet feeders:
	52 to 91 g/m <sup>2</sup> (14 to 24 lb)

## Single-sheet multipart forms: front and high-capacity cut-sheet feeder entry

Width	Front:
	90 to 304.8 mm (3.5 to 12 inches)
	High-capacity cut-sheet feeder:
	100 to 297 mm (3.9 to 11.7 inches)
Length	Front, top glue:
	70 to 420 mm (2.8 to 16.5 inches)
	Front, side glue:
	70 to 297 mm (2.8 to 11.7 inches)
	High-capacity cut-sheet feeder:
	70 to 420 mm (2.8 to 16.5 inches)
Copies	1 original + up to 5 copies

C

Thickness	0.12 to 0.46 mm (0.0047 to 0.018 inch)
Weight	40 to 58 g/m <sup>2</sup> (10 to 15 lb)
Binding	Front: Line glue at the top or a side of form High-capacity cut-sheet feeder: Line glue at the top of form

**Envelopes: front and high-capacity cut-sheet feeder entry**

Size	No. 6: 165 × 92 mm (6.5 × 3.6 inches) No. 10: 241 × 105 mm (9.5 × 4.1 inches)
Thickness	0.16 to 0.52 mm (0.0063 to 0.0205 inch)
Weight	45 to 90 g/m <sup>2</sup> (12 to 24 lb)

**Postcards: front and high-capacity cut-sheet feeder entry**

Width	100 to 200 mm (3.9 to 7.8 inches)
Length	100 to 200 mm (3.9 to 7.8 inches)
Thickness	0.22 mm (0.0087 inch)
Weight	192 g/m <sup>2</sup> (51 lb)

**Roll paper: rear entry with optional roll paper holder**

Width	216 ± 3 mm (8.5 ± 0.12 inches)
Thickness	0.07 to 0.09 mm (0.0028 to 0.0035 inch)
Weight	52 to 82 g/m <sup>2</sup> (14 to 22 lb)



### **Continuous paper (standard and multipart): rear entry**

Width	101.6 to 304.8 mm (4 to 12 inches)
Length (one page)	76.2 to 558.8 mm (3 to 22 inches)
Copies	1 original + up to 5 copies
Thickness	Printable area 0.065 to 0.46 mm (0.0025 to 0.018 inch) Gathering area up to 0.9 mm (0.035 inch)
Weight (not multipart)	52 to 128 g/m <sup>2</sup> (14 to 34 lb)
Weight (one sheet of multipart)	40 to 58 g/m <sup>2</sup> (10 to 15 lb)
Binding	Point glue or /and paper staples on both sides

#### **Note:**

- The ratio of the cut/uncut length at the perforation should be between 3:1 and 5:1.*
- The thickness of the perforation part when extended should be 2 mm or less.*
- The perforation between pages should not extend all the way to the edges of the paper. Uncut length on the edges should be 1 mm or more.*
- When the horizontal and vertical perforation cuts crossing, do not print in between 3 mm above and below the horizontal perforation and in between 28 mm left and right the vertical perforation.*

C

**Continuous paper with overlapping multipart forms  
(LQ-680Pro only): rear entry**

Width and length of the Same as standard continuous paper  
backing sheet

Copies 1 original + up to 5 copies

Thickness Printable area 0.065 to 0.46 mm  
(0.0025 to 0.018 inch)  
overlapping area up to 0.70 mm  
(0.028 inch)

other measurements See below

**Labels: rear entry**

Label size 23.8 × 63.5 mm (15/16 × 2.5 inches)  
minimum  
2.5 mm (0.1 inch) corner radius,  
minimum

Backing sheet width 101.6 to 304.8 mm (4 to 12 inches)

Backing sheet length 76.2 to 558.8 mm (3 to 22 inches)  
(one page)

Backing sheet thickness 0.07 to 0.09 mm (0.0028 to 0.0035 inch)

Total thickness 0.16 to 0.19 mm (0.0063 to 0.0075 inch)

Label weight 64 g/m<sup>2</sup> (17 lb)

## Printable area

Single sheets, envelopes, postcards, and roll paper:

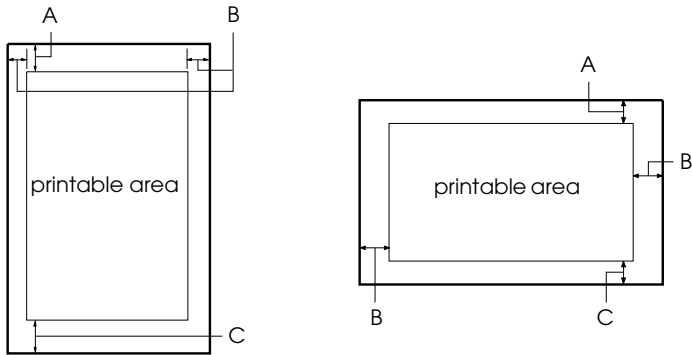

- A The minimum top margin is 0 mm (0 inch). For envelopes and postcards loaded from cut-sheet feeder, it is 4.2 mm (0.17 inch).
- B The minimum left and right margins are 3.0 mm (0.12 inch) each.  
The maximum printable width is 269.2 mm (10.6 inches).  
For single sheets wider than 275.2 mm (10.8 inches), the side margins increase proportionally to match the width of the paper.
- C The minimum bottom margin is 0 mm (0 inch).

C

Continuous paper (standard and multipart):

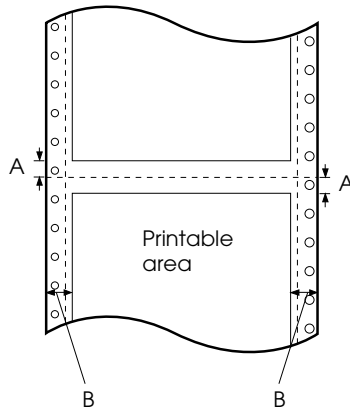

- A The minimum top and bottom margins above and below the perforation are 4.2 mm (0.17 inch) each.
- B The minimum left and right margins are 13 mm (0.51 inch) each.  
The maximum printable width is 269.2 mm (10.6 inches).  
For continuous paper wider than 295.2 mm (11.6 inches), the side margins increase proportionally to match the width of the paper.

Continuous paper with overlapping multipart forms:

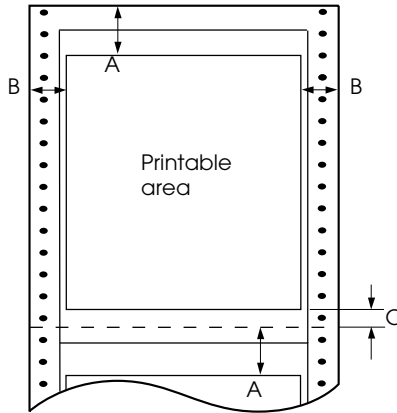

- A The minimum top margin from the perforation down to the printable area is 21.2 mm (0.83 inch).
- B The minimum left and right margins are 19 mm (0.75 inch) each.  
The maximum printable width is 266.8 mm (10.5 inches).
- C The minimum bottom margin from the printable area down to the perforation is 4.2 mm (0.17 inch) each.

C

## ***Safety approvals***

120 V model:

Safety standards	UL1950 CSA C22.2 No. 950
EMI	FCC part 15 subpart B class B CSA C108.8 class B

230 V model:

Safety standards	EN 60950
EMI	EN 55022 (CISPR pub. 22) class B AS/NZS 3548 class B

## ***CE marking***

230 V model:

Low Voltage Directive 73/23/EEC	EN 60950
EMC Directive 89/336/EEC	EN 55022 Class B EN 61000-3-2 EN 61000-3-3 EN 50082-1 EN 55024

---

## Command Lists

Your printer supports the following EPSON ESC/P2 control codes and IBM 2390 Plus emulation control codes:

### **EPSON ESC/P2 control codes**

Selecting an EPSON ESC/P2 printer in your software allows you to use advanced fonts and graphics.

General operation:

ESC @, ESC U, ESC EM

Paper feeding:

FF, LF, ESC 0, ESC 2, ESC 3, ESC +, CR

Page format:

ESC (C, ESC C, ESC C 0, ESC Q, ESC I, ESC (c, ESC N, ESC O

Print position motion:

ESC \$, ESC \, ESC (V, ESC (v, ESC D, HT, ESC B, VT, ESC J

Font selection:

ESC k, ESC x, ESC y, ESC X, ESC P, ESC M, ESC g, ESC p,  
ESC 4, ESC 5, ESC E, ESC F, ESC !

Font enhancement:

ESC W, DC4, SO, DC2, SI, ESC w, ESC G, ESC H, ESC T,  
ESC S, ESC -, ESC (-, ESC q

Spacing:

ESC Space, ESC c, ESC (U

Character handling:

ESC t, ESC (t, ESC R, ESC %, ESC &, ESC :, ESC 6, ESC 7, ESC (^

Bit image:

ESC \*

Bar code:

ESC (B

C

## **IBM 2390 Plus emulation control codes**

This printer emulates the IBM Proprinter using the commands below. For detailed information, see the IBM 2390 Plus reference manual.

General operation:

NUL, DC3, ESC j, BEL, CAN, DC1, ESC Q, ESC [ K, ESC U,  
ESC [ F

Paper feeding:

FF, LF, ESC 5, ESC A, ESC A (AGM\*), ESC 0, ESC 1, ESC 2,  
ESC 3, ESC 3 (AGM\*), CR, ESC ]

Page format:

ESC C, ESC C0, ESC X, ESC N, ESC O, ESC 4

Print position motion:

ESC d, ESC R, ESC D, HT, ESC B, VT, ESC J, ESC J (AGM\*)

Font selection:

DC2, ESC P, ESC :, ESC E, ESC F, ESC I, ESC [d, ESC [I

Font enhancement:

DC4, SO, ESC SO, ESC W, ESC [ @, SI, ESC SI, ESC G, ESC H,  
ESC T, ESC S, ESC -, ESC \_, ESC [-

Spacing:

BS, SP, ESC [ \

Character handling:

ESC 6, ESC 7, ESC [ T, ESC ^, ESC \

Bit image:

ESC K, ESC L, ESC Y, ESC Z, ESC [g, ESC \* (AGM\*)

\* Alternate Graphic Mode

Barcode:

ESC [f, ESC [p

Download:

Download command is not provided.



---

***Customer Support Information***

Contacting Customer Support . . . . . D-2

For Users in North America . . . . . D-3

For Users in the United Kingdom and the  
Republic of Ireland . . . . . D-4

For Users in Australia . . . . . D-6

For Users in India . . . . . D-7

For Users in Malaysia . . . . . D-8

For Users in Singapore . . . . . D-8

For Users in Hong Kong . . . . . D-9

For Users in the Philippines . . . . . D-10



---

## **Contacting Customer Support**

If your EPSON product is not operating properly and you cannot solve the problem using the troubleshooting information in your product documentation, contact customer support services for assistance. If customer support for your area is not listed below, contact the dealer where you purchased your product.

Customer support will be able to help you much more quickly if you give them the following information.

- Product serial number  
(The serial number label is usually on the back of the product.)
- Product model
- Product software version  
(Click About, Version Info, or similar button in the product software.)
- Brand and model of your computer
- Your computer operating system name and version
- Names and versions of the software applications you normally use with your product

---

## For Users in North America

If you purchased your printer in the United States or Canada, EPSON provides technical assistance 24 hours a day through the electronic support services and automated telephone services listed in the following table:

Service	Access
World Wide Web	From the Internet, you can reach EPSON Support at <a href="http://support.epson.com">http://support.epson.com</a> . At this site, you can download drivers and other files, look at documentation such as product brochures and user manuals, and access troubleshooting information.
EPSON Internet FTP Site	If you have Internet FTP capability, use your Web browser (or other software for FTP downloading) to log onto <a href="ftp.epson.com">ftp.epson.com</a> with the user name <b>anonymous</b> and your e-mail address as the password.
EPSON E-MAIL Technical Support	To receive technical advice through e-mail, go to <a href="http://support.epson.com">http://support.epson.com</a> and complete the form under the troubleshooting tab, as requested.
Automated Telephone Services	A variety of automated help services are available 24 hours a day, seven days a week. To use these services, you must have a touch tone telephone and call <b>(800) 922-8911</b> .

To speak directly to a technical support representative, dial: **(562) 276-4322** (U.S.), or **(905) 709-2170** (Canada), 6 AM to 6 PM, Pacific Time, Monday through Friday. Toll or long distance charges may apply.

Before you call, please have the following information ready:

- Product name
- Product serial number (located on the back of the printer)
- Proof of purchase (such as a store receipt) and date of purchase

- ❑ Computer configuration
- ❑ Description of the problem

**Note:**

*For help using any other software on your system, see the documentation for that software for technical support information.*

You can purchase ink cartridges, ribbon cartridges, paper, manuals, and accessories from EPSON at **(800) 873-7766** or visit our web site at **www.epsonsupplies.com** (U.S. sales only). In Canada, please call **(800) 873-7766** for dealer referral.

---

## ***For Users in the United Kingdom and the Republic of Ireland***

If you purchased your product in the UK or the Republic of Ireland, EPSON (UK) LTD provides a range of customer services and technical support.

### *Support Via the World Wide Web*

- ❑ For information on the latest EPSON products, software drivers, online user guides, and answers to frequently asked questions:

<http://www.epson.co.uk>

- ❑ To e-mail EPSON Technical Support:

<http://www.epson.co.uk/support/email/>

- ❑ For a full list of EPSON Customer and Warranty Support services:

<http://www.epson.co.uk/support/>

## *Support Via Telephone*

Our Customer and Warranty Support teams can be contacted by calling 0870 163 7766 in the UK or 0044 0870 163 7766 from the Republic of Ireland. They can provide the following services:

- ❑ Technical information on installing, configuring, and operating your EPSON products
- ❑ Arranging for faulty EPSON products to be repaired within the warranty period

## *Pre-Sales Enquiry Desk*

Our Enquiry Desk team can be contacted by calling 0800 220546 in the UK or 1 800 409132 from the Republic of Ireland, by faxing 01442 227271 in the UK or 0044 1442 227271 from the Republic of Ireland, and via e-mail at [info@epson.co.uk](mailto:info@epson.co.uk). They can provide the following information:

- ❑ Pre-sales information and literature on new EPSON products (also available via our world wide web site at <http://www.epson.co.uk>)
- ❑ Where to purchase genuine EPSON consumables, accessories, and options

---

## ***For Users in Australia***

EPSON Australia wishes to provide you with a high level of customer service. In addition to your product documentation, we provide the following sources for obtaining information:

### *Your Dealer*

Don't forget that your dealer can often help identify and resolve problems. The dealer should always be the first call for advise on problems, they can often solve problems quickly and easily as well as give advise on the next step to take.

### *Internet URL <http://www.epson.com.au>*

Access the EPSON Australia World Wide Web pages. Worth taking your modem here for the occasional surf! The site provides a download area for drivers, EPSON contact points, new product information and technical support (e-mail).

### *EPSON Faxback service*

EPSON Faxback service will fax you the latest specifications for most EPSON products offered in Australia. Phone (02) 9903 9075 and the system will guide you through a number of choices before faxing the information to your fax machine.

### *EPSON Helpdesk*

EPSON Helpdesk is provided as a final backup to make sure our clients have access to advice. Operators on the Helpdesk can aid you in installing, configuring and operating your EPSON product. Our Pre-sales Helpdesk staff can provide literature on new EPSON products and advise where the nearest dealer or service agent is located. Many types of queries are answered here.

The Helpdesk numbers are:

Phone: 1300 361 054

Fax: (02) 9903 9189

We encourage you to have all the relevant information on hand when you ring. The more information you prepare, the faster we can help solve the problem. This information includes your EPSON product documentation, type of computer, operating system, application programs, and any information you feel is required.

---

## ***For Users in India***

Contacts for information, support, and services are:

*World Wide Web (www.epson.co.in)*

Information on product specifications, drivers for download, Frequently Asked Questions (FAQ), Products Enquiry, and Technical Query are available.

*Epson India Bangalore Head Office:*

Phone: 080 5095465

Fax: 080 5095474

**D**

---

## ***For Users in Malaysia***

Contacts for information, support, and services are:

*World Wide Web (www.epson.com.my)*

Information on product specifications, drivers for download, Frequently Asked Questions (FAQ), and Email Enquiries are available.

*Epson Trading Shah Alam Head Office*

Phone: 03 5191366

Fax: 03 5191281

---

## ***For Users in Singapore***

Sources of information, support, and services available from Epson Singapore are:

*World Wide Web (www.epson.com.sg)*

Information on product specifications, drivers for download, Frequently Asked Questions (FAQ), Sales Enquiries, and Technical Support via e-mail are available.

*Epson HelpDesk (Phone: (065) 5863111)*

Our HelpDesk team can help you with the following over the phone:

- Sales enquiries and product information
- Product usage questions or problem
- Enquiries on repair service and warranty



---

## ***For Users in Hong Kong***

To obtain technical support as well as other after-sales services, users are welcome to contact EPSON Hong Kong Limited.

### *Internet home page*

EPSON Hong Kong has established a local home page in both Chinese and English on the Internet to provide users with the following information:

- Product information
- Answers to Frequently Asked Questions (FAQs)
- Latest versions of EPSON product drivers

Users can access our World Wide Web home page at:

<http://www.epson.com.hk>

### *Electronic bulletin board system*

An electronic bulletin board system (BBS) is also available to obtain product information and the latest versions of product drivers. You can log on to the following number for the BBS service:

BBS: (852) 2827-4244

### *Technical Support Hotline*

You can also contact our technical staff at the following telephone and fax numbers:

Phone: (852) 2585-4399

Fax: (852) 2827-4383

**D**

---

## ***For Users in the Philippines***

To obtain technical support as well as other after sales services, users are welcome to contact the EPSON Philippines Representative Office at the telephone and fax numbers below:

Phone: (632) 813-6552

Fax: (632) 813-6545

BBS: (632) 814-0595

---

# Glossary

**auto line feed**

When this option is turned on in the default-setting mode or the EPSON Remote! utility, each carriage return (CR) code is automatically followed by a line feed (LF) code.

**bidirectional printing**

Printing in which the print head prints in both directions (bidirectionally), from left to right and then right to left. This increases the print speed but may reduce precise vertical alignment. See also *unidirectional printing*.

**character table**

A collection of letters, numbers, and symbols that provides you with the set of characters used in a particular language.

**characters per inch (cpi)**

The number of characters that can fit in one inch of a text line, determined by the size of the characters. See also *pitch*.

**continuous paper**

Paper that has sprocket-feed holes on both long edges, is perforated between pages, and is supplied in a folded stack. Also called fanfold paper.

**control codes**

Special codes used to control printer functions, such as a carriage return or line feed, instead of printing characters.

**cpi**

See *characters per inch (cpi)*.

**cut-sheet feeder**

An device that automatically feeds single sheets of paper into the printer.

**default**

Value settings or settings that take effect when a device (such as a printer) is turned on, reset, or initialized.

**dithering**

A halftoning method in which dots are printed in a predetermined pattern to simulate a shade or tone. Dithering works best for images with solid colors, such as charts and graphs. See also *halftoning*.

**dot matrix**

A method of printing in which each letter or symbol is formed by a pattern (matrix) of individual dots.

**draft**

The print mode used by your printer when you select Draft as the font. The Draft font uses fewer dots per character for faster printing. See also *letter quality*.

**driver**

See *printer driver*.

**ESC/P**

Abbreviation for EPSON Standard Code for Printers, the system of commands your computer uses to control your printer. It is standard for all EPSON printers and supported by most application software for personal computers.

**ESC/P2**

The enhanced version of the ESC/P printer command language.

**fanfold paper**

See *continuous paper*.

**font**

A style of type designated by a name such as Roman or Sans Serif.

**form feed (FF)**

A control panel button and control code that advances the paper to the next top-of-form position.

**halftoning**

A method of using dot patterns to represent an image. Halftoning makes it possible to produce varying shades of gray using only black dots, or a nearly infinite array of colors using only a few colors of dots. See also *dithering*.

**hex dump**

A troubleshooting feature that helps identify the cause of communication problems between the printer and the computer. When the printer is in hex dump mode, it prints each code that it receives in hexadecimal notation as well as in ASCII codes that stand for characters. Also called data dump.

**interface**

The connection (via a cable) between the computer and the printer through which print data is transmitted to the printer.

**landscape**

Printing that is oriented sideways on the page. This orientation gives you a page that is wider than it is high and is useful for printing spreadsheets. See also *portrait*.

**letter quality (LQ)**

The print mode used by your printer, printing with **letter-quality** fonts provides better readability and appearance at a reduced print speed. See also *draft*.

**line feed (LF)**

A control panel button and control code that advances the paper one line space.

**micro adjust**

A printer feature that allows you to precisely adjust the tear-off and top-of-form positions.

**pitch**

The horizontal size of the font, which is measured in the number of character per inch (cpi). The standard is 10 cpi. See also *characters per inch (cpi)*.

**portrait**

Printing that is oriented upright on the page (as opposed to landscape, in which printing is sideways on the page). This is the standard orientation for printing letters or documents. See also *landscape*.

**printer driver**

A software program that sends commands for using the functions of a particular printer.

**resolution**

A measure of the amount of detail that can be represented. Resolution of printed images is measured by using the number of dots per inch (dpi).

**self test**

A method for checking the operation of the printer. When you run the self test, an internally stored self-pattern is printed.

**standby position**

The position of your continuous paper when it is attached to the tractor but not loaded in the printer.

**tear-off position**

The position of your continuous paper where you can tear off your printed pages at the printer's tear-off edge. Using the micro adjust feature, you can adjust the tear-off position so that the paper's perforation is aligned with the tear-off edge.

**top-of-form position**

The position on the paper that the printer recognizes as the first printable line. This is the default top margin position. Using the micro adjust feature, you can adjust the top-of-form position.

**unidirectional printing**

Printing in which the print head prints in one direction only. Unidirectional printing is useful for printing graphics because it provides precise vertical alignment. You can select unidirectional printing using the printer's default-setting mode or the EPSON Remote! utility. See also *bidirectional printing*.



---

# Index

## Numerics

0 slash, 4-6

## A

A.G.M. (Alternate Graphic Mode), 4-8

Adjusting

loading position, 2-28 to 2-30

paper thickness, 2-6 to 2-7

printing position, 2-32

tear-off position, 2-31 to 2-32

Aligning vertical lines, 5-17

Auto CR (carriage return), 4-8

Auto I/F (interface) wait time, 4-7

Auto line feed, 4-5

Auto position. *See* Paper thickness lever

Auto tear-off, 2-16 to 2-17, 4-5

## B

Bidirectional (Bi-d) printing. *See* Print direction

Bidirectional adjustment mode. *See* Aligning vertical lines

Bit rate, A-19

Built-in font

list, C-4

selecting, 4-2, 4-8

Button

Paper Source, 2-2, 2-5, 2-9, 2-21, 2-27, 2-28, A-10, A-12

Tear Off/Bin, 2-15, 2-20, 2-25, 2-27, A-10, A-12, A-13

Tear Off/Special Paper, 2-15, 2-19, 2-20, 2-24, 2-25, 2-27, A-13

Buzzer (beeper) setting, 4-9

## C

Cards. *See* Interface cards or Postcards

Character table

list, C-5

setting, 4-8

Condensed, selecting, 4-2

Continuous paper

loading, 2-9 to 2-14

problems, 5-8

removing, 2-17

switching to and from, 2-26 to 2-28, A-13 to A-14

Control panel, 2-2 to 2-32, 4-2 to 4-10, 5-2, A-10 to A-18

overview, inside front cover

Customer support, D-2 to D-10

Cut-sheet feeders, A-2 to A-15

installing, A-3 to A-6

loading paper from, A-6 to A-12

switching between continuous paper and, A-13 to A-14

## D

Default settings

changing, 4-9 to 4-10

option list, 4-3 to 4-4

Driver. *See* Printer driver

## E

Edge guide, 2-22

Electrical, C-6

Emulation. *See* IBM 2390 Plus emulation

ENERGY STAR compliance, 4

Envelopes, 2-24 to 2-25

EPSON Remote! utility, 1-12, 3-2, 3-19

EPSON Status Monitor 3 utility, 1-12, 3-2, 3-20 to 3-22

Error indication, 5-2 to 5-3  
ESC/P 2, C-15

## **F**

Font (default setting), 4-8  
Font. *See* built-in font

## **H**

Hex dump, 5-19 to 5-20  
High speed draft (default setting), 4-6

## **I**

I/F (interface) mode, 4-7  
IBM 2390 Plus emulation, C-16  
Installing  
    cut-sheet feeders, A-3 to A-6  
    interface cards, A-20 to A-21  
    ribbon cartridge, 1-8 to 1-11  
Interface cards, A-19 to A-21  
International character set for Italic  
    table, 4-8  
International character sets, C-5

## **L**

Labels, 2-19 to 2-20  
Lever  
    paper release, 2-4  
    paper thickness, 2-6 to 2-7

## **M**

Manual feed wait time, 4-9  
Micro Adjust  
    loading position, 2-28 to 2-30  
    printing position, 2-32  
    tear-off position, 2-31 to 2-32  
Multipart forms  
    continuous, 2-17 to 2-18  
    single-sheet, 2-23 to 2-24

## **O**

Options  
    cut-sheet feeders, A-2 to A-15  
    interface cards, A-19 to A-21  
    roll-paper holder, A-15 to A-18  
Overlapping forms (default setting), 4-9  
Overlapping multipart forms, 2-18 to 2-19

## **P**

Packet mode, 4-7  
Page length for tractor, 4-5  
Paper, 2-28  
Paper capacity, C-3  
Paper jam, clearing, 5-16  
Paper release lever, 2-4  
Paper source, selecting, 2-2 to 2-5  
Paper Source button, 2-2, 2-5, 2-9, 2-21, 2-27, 2-28, A-10, A-12  
Paper specifications, C-6 to C-10  
Paper thickness lever, 2-6 to 2-7  
Parallel I/F (interface) bidirectional mode, 4-7  
Pitch. *See* Condensed  
Plugging in the printer, 1-5 to 1-6  
Postcards, 2-25 to 2-26  
Printable area, C-11 to C-13  
Print direction, 4-6  
Printer driver  
    accessing  
        from Windows 2000 or NT 4.0, 3-9 to 3-12  
        from Windows 3.1, 3-6 to 3-8  
        from Windows 98 or 95, 3-3 to 3-5  
        from Windows NT 3.5x, 3-13 to 3-16



- installing
  - for DOS, 1-16
  - for Windows 2000 or NT 4.0, 1-13 to 1-14
  - for Windows 3.1, 1-14 to 1-15
  - for Windows 98 or 95, 1-13 to 1-14
  - for Windows NT 3.5x, 1-14 to 1-15
- settings, 3-17 to 3-18
- Printer software, installing, 1-12 to 1-16

## **R**

- Remote! utility. *See* EPSON Remote! utility
- Removing
  - continuous paper, 2-17
  - labels, 2-20
  - roll paper, A-18
- Ribbon cartridge, installing or replacing, 1-8 to 1-11
- Roll-paper holder, A-15 to A-18

## **S**

- Safety instructions, 2 to 3
- Self test, 5-18 to 5-19
- Single sheets
  - problems, 5-6 to 5-7
  - using, 2-20 to 2-23
- Skip over perforation, 4-5
- Software
  - default setting, 4-6
  - installing, 1-12 to 1-16
- Specifications
  - built-in font, C-4
  - CE marking, C-14
  - character tables, C-5
  - command lists
    - ESC/P 2, C-15
    - IBM 2390 Plus emulation, C-16
  - environmental, C-6

- international character sets, C-5
- mechanical, C-2 to C-3
- paper, C-6 to C-10
- paper capacity, C-3
- printable area, C-11 to C-13
- safety approvals, C-14
- Status Monitor 3 utility. *See* EPSON Status Monitor 3 utility
- Switching between continuous paper and single sheets, 2-26 to 2-28, A-13 to A-14

## **T**

- Tear Off/Bin button, 2-15, 2-20, 2-25, 2-27, A-10, A-12, A-13
- Tear Off/Special Paper button, 2-15, 2-19, 2-20, 2-24, 2-25, 2-27, A-13
- Tear-off function, 2-14 to 2-17
- Thickness. *See* Paper thickness lever
- Troubleshooting
  - continuous paper loading or feeding problems, 5-8
  - power supply problems, 5-5
  - printing or printout quality problems, 5-11 to 5-15
  - printing position problems, 5-9
  - single-sheet paper loading or feeding problems, 5-6 to 5-7

## **U**

- Unidirectional (Uni-d) printing. *See* Print direction



## Printer Parts

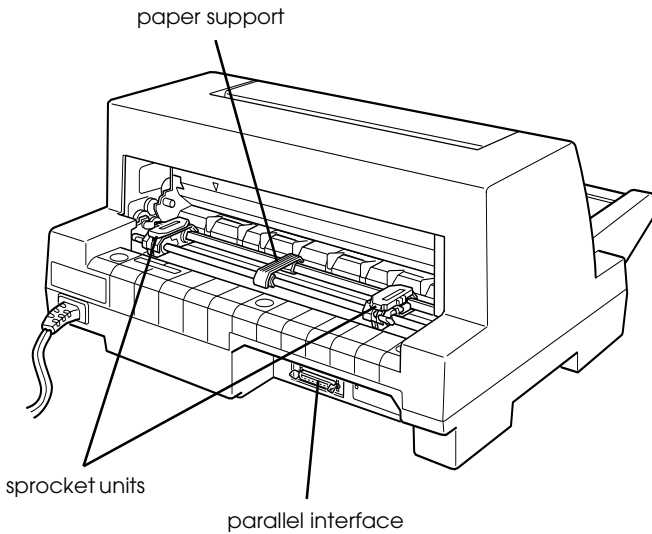
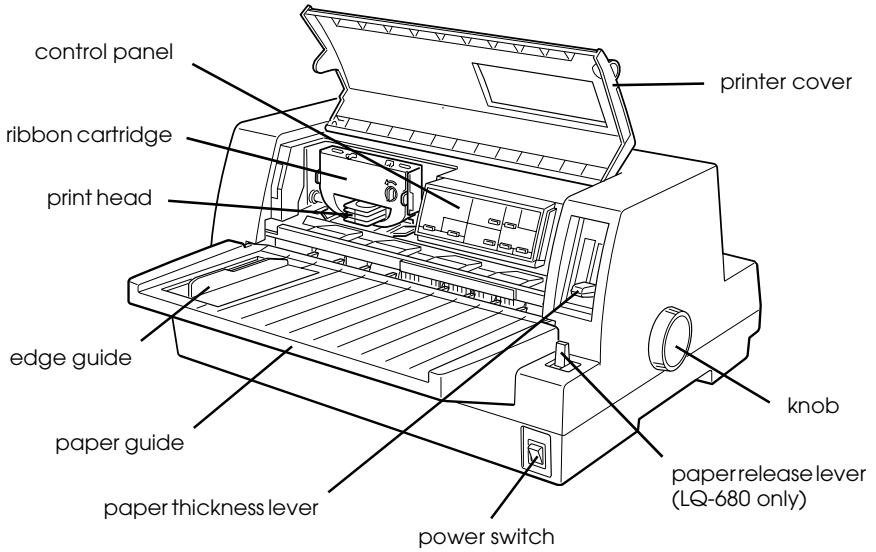

<b>EPSON OVERSEAS MARKETING LOCATIONS</b>
---

---

**EPSON AMERICA, INC.**

20770 Madrona Ave.  
P.O. Box 2842  
Torrance, CA 90509-2842  
Phone: (800) 922-8911  
Fax: (310) 782-5220

**EPSON UK LTD.**

Campus 100, Maylands Avenue,  
Hemel Hempstead, Herts,  
HP2 7TJ, U.K.  
Phone: (+44) 01442 261144  
Fax: (+44) 01442 227227

---

**EPSON DEUTSCHLAND GmbH**

Zülpicher Straße 6,  
40549 Düsseldorf Germany  
Phone: (0211) 56030  
Fax: (0211) 5047787

**EPSON FRANCE S.A.**

68 bis, rue Marjolín  
92300, Levallois-Perret, France  
Phone: 33.1.40.87.37.37  
Telex: 610657

---

**EPSON AUSTRALIA PTY. LTD.**

70 GIBBES STREET, CHATSWOOD 2067 NSW.  
Phone: 2-9903-9000  
Fax: 2-9903-9177

**EPSON SINGAPORE PTE. LTD.**

No. 1 Temasek Avenue #36-00  
Millenia Tower, Singapore 039192  
Phone: (065) 33 77 911  
Fax: (065) 33 41 185

---

**EPSON HONG KONG LTD.**

Rooms 4706-10, 47/F,  
China Resources Bldg.,  
26 Harbour Road, Wanchai, Hong Kong  
Phone: 2585-4300  
Fax: 2827-7083

**EPSON TAIWAN TECHNOLOGY & TRADING LTD.**

10F, No. 287 Nanking E. Road, Sec. 3,  
Taipei, Taiwan, R.O.C.  
Phone: (02) 717-7360  
Fax: (02) 712-9164

---

**EPSON ITALIA S.p.A.**

V.le F.lli Casiraghi 427  
20099 Sesto S.Giovanni  
MI, Italy  
Phone: 2-262331  
Fax: 2-2440750

**EPSON IBERICA S.A.**

Av. de Roma, 18-26  
08290 Cerdanyola del Valles  
Barcelona, Spain  
Phone: 582. 15.00  
Fax: 582. 15.55

---

**SEIKO EPSON CORPORATION****(Hirooka Office)**

80 Harashinden, Hirooka  
Shiojiri-shi, Nagano-ken  
399-0785 Japan

**EPSON PORTUGAL, S.A.**

R. do Progresso, 471, 1º Perafita  
4460 Matosinhos, Portugal  
Phone: (02) 996 14 02  
Fax: (02) 996 14 11

**EPSON**

24-Pin Dot  
Matrix Printer

**LQ-680/LQ-680Pro**

*User's Guide*

Printed in Japan  
00,XX-XX